

# Mathematics 1

Mathematics Department  
Phillips Exeter Academy  
Exeter, NH  
August 2009



## To the Student

**Contents:** Members of the PEA Mathematics Department have written the material in this book. As you work through it, you will discover that algebra, geometry, and trigonometry have been integrated into a mathematical whole. There is no Chapter 5, nor is there a section on tangents to circles. The curriculum is problem-centered, rather than topic-centered. Techniques and theorems will become apparent as you work through the problems, and you will need to keep appropriate notes for your records — there are no boxes containing important theorems. There is no index as such, but the reference section that starts on page 201 should help you recall the meanings of key words that are defined in the problems (where they usually appear italicized).

**Comments on problem-solving:** You should approach each problem as an exploration. Reading each question carefully is essential, especially since definitions, highlighted in italics, are routinely inserted into the problem texts. It is important to make accurate diagrams whenever appropriate. Useful strategies to keep in mind are: create an easier problem, guess and check, work backwards, and recall a similar problem. It is important that you work on each problem when assigned, since the questions you may have about a problem will likely motivate class discussion the next day.

Problem-solving requires persistence as much as it requires ingenuity. When you get stuck, or solve a problem incorrectly, back up and start over. Keep in mind that you're probably not the only one who is stuck, and that may even include your teacher. If you have taken the time to think about a problem, you should bring to class a written record of your efforts, not just a blank space in your notebook. The methods that you use to solve a problem, the corrections that you make in your approach, the means by which you test the validity of your solutions, and your ability to communicate ideas are just as important as getting the correct answer.

**About technology:** Many of the problems in this book require the use of technology (graphing calculators or computer software) in order to solve them. Moreover, you are encouraged to use technology to explore, and to formulate and test conjectures. Keep the following guidelines in mind: write before you calculate, so that you will have a clear record of what you have done; store intermediate answers in your calculator for later use in your solution; pay attention to the degree of accuracy requested; refer to your calculator's manual when needed; and be prepared to explain your method to your classmates. Also, if you are asked to “graph  $y = (2x - 3)/(x + 1)$ ”, for instance, the expectation is that, although you might use your calculator to generate a picture of the curve, you should sketch that picture in your notebook or on the board, with correctly scaled axes.



Phillips Exeter Academy

Introductory Math Guide for New Students  
(For students, by students!)



## Introduction

Annually, approximately 300 new students take up studies in the Mathematics Department. Coming from various styles of teaching, as a new student you will quickly come to realize the distinct methods and philosophies of teaching at Exeter. One aspect of Exeter that often catches students unaware is the math curriculum. I encourage all new students to come to the math table with a clear mind. You may not grasp, understand, or even like math at first, but you will have to be prepared for anything that comes before you.

During the fall of 2000, the new students avidly voiced a concern about the math curriculum. Our concern ranged from grading, to math policies, and even to the very different teaching styles utilized in the mathematics department. The guide that you have begun reading was written solely by students, with the intent of preparing you for the task that you have embarked upon. This guide includes tips for survival, testimonials of how we felt when entering the math classroom, and aspects of math that we would have liked to have known, before we felt overwhelmed. Hopefully, this guide will ease your transition into math at Exeter. Remember, “Anything worth doing, is hard to do.” Mr. Higgins ’36.

— Anthony L. Riley ’04

*“I learned a lot more by teaching myself than by being taught by someone else.”*

*“One learns many ways to do different problems. Since each problem is different, you are forced to use all aspects of math.”*

*“It takes longer for new concepts to sink in . . . you understand, but because it didn’t sink in, it’s very hard to expand with that concept.”*

*“It makes me think more. The way the math books are setup (i.e. simple problems progressing to harder ones on a concept) really helps me understand the mathematical concepts.”*

*“When you discover or formulate a concept yourself, you remember it better and understand the concept better than if we memorized it or the teacher just told us that the formula was ‘xyz’.”*

## Homework

Math homework = no explanations and eight problems a night. For the most part, it has become standard among most math teachers to give about eight problems a night; but I have even had a teacher who gave ten — though two problems may not seem like a big deal, it can be. Since all the problems are scenarios, and often have topics that vary, they also range in complexity, from a simple, one-sentence question, to a full-fledged paragraph with an eight-part answer! Don’t fret though, transition to homework will come with time, similar to how you gain wisdom, as you get older. Homework can vary greatly from night to night, so be flexible with your time — this leads to another part of doing your homework. IN ALL CLASSES THAT MEET FIVE TIMES A WEEK, INCLUDING MATHEMATICS, YOU SHOULD SPEND 50 MINUTES AT THE MAXIMUM, DOING HOMEWORK! No teacher should ever expect you to spend more time, with the large workload Exonians carry. Try your hardest to concentrate, and utilize those 50 minutes as much as possible.

Without any explanations showing you exactly how to do your homework, how are you supposed to do a problem that you have absolutely no clue about? (This WILL happen!) Ask somebody in your dorm. Another person in your dorm might be in the same class, or the same level, and it is always helpful to seek the assistance of someone in a higher level of math. Also remember, there is a difference between homework and studying; after you're through with the eight problems assigned to you, go back over your work from the last few days.

*“...with homework, you wouldn't get marked down if you didn't do a problem.”*

### **Going to the Board**

It is very important to go to the board to put up homework problems. Usually, every homework problem is put up on the board at the beginning of class, and then they are discussed in class. If you regularly put problems up on the board, your teacher will have a good feel of where you stand in the class; a confident student will most likely be more active in participating in the class.

### **Plagiarism**

One thing to keep in mind is plagiarism. You can get help from almost anywhere, but make sure that you cite your help, and that all work shown or turned in is your own, even if someone else showed you how to do it. Teachers do occasionally give problems/quizzes/tests to be completed at home. You may not receive help on these assessments, unless instructed to by your teacher; it is imperative that all the work is yours.

### **Math Extra-Help**

Getting help is an integral part of staying on top of the math program here at Exeter. It can be rather frustrating to be lost and feel you have nowhere to turn. There are a few tricks of the trade however, which ensure your “safety,” with this possibly overwhelming word problem extravaganza.

### **Teachers and Meetings**

The very first place to turn for help should be your teacher. Since teachers at Exeter have many fewer students than teachers at other schools, they are never less than eager to help you succeed in any way they can. There is actually one designated time slot a week for students to meet with teachers, which is meetings period on Saturday. You can always call or ask a teacher for help. If there is no time during the day, it is always possible to check out of the dorm after your check-in time, to meet with your teacher at their apartment, or house. It is easiest to do this on the nights that your teacher is on duty in his/her dorm. Getting help from your teacher is the first and most reliable source to turn to, for extra help.

*“You could meet with the teacher for extra help anytime.”*

*“Extra help sessions one-on-one with the teacher. My old math text.”*



## 7-9 Math Help

Along with help from your teacher, there are several other places to get help. From 7-9 PM every night, except Saturday, there is a Math and Science help group in the Science Center. Each evening, the lab is filled with students in a broad range of math levels, which should be able to help you with problems you have. Also, remember that your homework is not graded everyday, and your teacher will usually tell you when he/she will be grading a particular assignment. This means that you can always find someone in your dorm that will help you catch up or simply help you with a tough problem. If you are a day student, I would definitely recommend going to Science and Math Help.

*“...harder to understand concepts if you don’t understand a problem because each problem is trying to teach you something different that leads to a new concept.”*

*“Hard to separate different math concepts. Not sure what kind of math it is I’m learning. More difficult to review.”*

### Different Teachers Teach Differently

The teachers at Exeter usually develop their own style of teaching, fitted to their philosophy of the subject they teach; it is no different in the math department. Teachers vary at all levels: they grade differently, assess your knowledge differently, teach differently, and go over homework differently. They offer help differently, too. This simply means that it is essential that you be prepared each term to adapt to a particular teaching style. For instance, my teacher tests me about every two weeks, gives hand-in problems every couple of days, and also gives a few quizzes. However, my friend, who is in the same level math as I am, has a teacher who doesn’t give any tests or quizzes; he only grades on class participation, and assigns a single hand-in problem, each assignment. Don’t be afraid to ask your teacher how they grade, because this can become very crucial; various teachers put more weight on class participation in grading while others do the opposite. You must learn to be flexible to teaching styles and even your teacher’s personality. This is a necessity for all departments at Exeter, including math.

*“The tests are the hardest part between terms to adapt to, but if you prepare well, there shouldn’t be a problem.”*

*“Tests are hard. Can’t go at your own pace.”*

*“My other teacher taught and pointed out which problems are related when they are six pages apart.”*

*“It took a few days adjusting to, but if you pay attention to what the teacher says and ask him/her questions about their expectations, transitions should be smooth.”*

*“Inconsistent. Every teacher gave different amounts of homework and tests. Class work varied too. My fall term teacher made us put every problem on the board, whereas my winter term teacher only concentrated on a few.”*

— Jonathan Barbee ’04

— Ryan Levihn-Coon ’04

## New Student Testimonials

*“There was not a foundation to build on. There were no ‘example’ problems.”*

After eight years of math textbooks and lecture-style math classes, math at Exeter was a lot to get used to. My entire elementary math education was based on reading how to do problems from the textbook, then practicing monotonous problems that had no real-life relevance, one after the other. This method is fine for some people, but it wasn't for me. By the time I came to Exeter, I was ready for a change of pace, and I certainly got one.

Having somewhat of a background in algebra, I thought the Transition 1 course was just right for me. It went over basic algebra and problem-solving techniques. The math books at Exeter are very different from traditional books. They are compiled by the teachers, and consist of pages upon pages of word problems that lead you to find your own methods of solving problems. The problems are not very instructional, they lay the information down for you, most times introducing new vocabulary, (there is an index in the back of the book), and allow you to think about the problem, and solve it any way that you can. When I first used this booklet, I was a little thrown back; it was so different from everything I had done before — but by the time the term was over, I had the new method down.

The actual math classes at Exeter were hard to get used to as well. Teachers usually assign about eight problems a night, leaving you time to “explore” the problems and give each one some thought. Then, next class, students put all the homework problems on the board. The class goes over each problem; everyone shares their method and even difficulties that they ran into while solving it. I think the hardest thing to get used to, is being able to openly ask questions. No one wants to be wrong, I guess it is human nature, but in the world of Exeter math, you can't be afraid to ask questions. You have to seize the opportunity to speak up and say “I don't understand,” or “How did you get that answer?” If you don't ask questions, you will never get the answers you need to thrive.

Something that my current math teacher always says is to make all your mistakes on the board, because when a test comes around, you don't want to make mistakes on paper. This is so true, class time is practice time, and it's hard to get used to not feeling embarrassed after you answer problems incorrectly. You need to go out on a limb and try your best. If you get a problem wrong on the board, it's one new thing learned in class, not to mention, one less thing to worry about messing up on, on the next test.

Math at Exeter is really based on cooperation, you, your classmates, and your teacher. It takes a while to get used to, but in the end, it is worth the effort.

— Hazel Cipolle '04

*“At first, I was very shy and had a hard time asking questions.*

*“Sometimes other students didn’t explain problems clearly.”*

*“Solutions to certain problems by other students are sometimes not the fastest or easiest.  
Some students might know tricks and special techniques that aren’t covered.”*

I entered my second math class of Fall Term as a ninth grader, with a feeling of dread. Though I had understood the homework the night before, I looked down at my paper with a blank mind, unsure how I had done any of the problems. The class sat nervously around the table until we were prompted by the teacher to put the homework on the board. One boy stood up and picked up some chalk. Soon others followed suit. I stayed glued to my seat with the same question running through my mind, what if I get it wrong?

I was convinced that everyone would make fun of me, that they would tear my work apart, that each person around that table was smarter than I was. I soon found that I was the only one still seated and hurried to the board. The only available problem was one I was slightly unsure of. I wrote my work quickly and reclaimed my seat.

We reviewed the different problems, and everyone was successful. I explained my work and awaited the class’ response. My classmates agreed with the bulk of my work, though there was a question on one part. They suggested different ways to find the answer and we were able to work through the problem, together.

I returned to my seat feeling much more confident. Not only were my questions cleared up, but my classmates’ questions were answered as well. Everyone benefited.

I learned one of the more important lessons about math at Exeter that day; it doesn’t matter if you are right or wrong. Your classmates will be supportive of you, and tolerant of your questions. Chances are, if you had trouble with a problem, someone else in the class did too. Another thing to keep in mind is that the teacher expects nothing more than that you try to do a problem to the best of your ability. If you explain a problem that turns out to be incorrect, the teacher will not judge you harshly. They understand that no one is always correct, and will not be angry or upset with you.

— Elisabeth Ramsey ’04

*“My background in math was a little weaker than most people’s, therefore I was unsure how to do many of the problems. I never thoroughly understood how to do a problem before I saw it in the book.”*

I never thought math would be a problem. That is, until I came to Exeter. I entered into Math T1B, clueless as to what the curriculum would be. The day I bought the Math One book from the Bookstore Annex, I stared at the problems in disbelief. ALL WORD PROBLEMS. “Why word problems?” I thought. I had dreaded word problems ever since I was a second grader, and on my comments it always read, “Charly is a good math student, but she needs to work on word problems.” I was in shock. I would have to learn math in an entirely new language. I began to dread my B format math class.

My first math test at Exeter was horrible. I had never seen a D– on a math test. Never. I was upset and I felt dumb, especially since others in my class got better grades, and because my roommate was extremely good in math. I cried. I said I wanted to go home where things were easier. But finally I realized, “I was being given a challenge. I had to at least try.”

I went to my math teacher for extra help. I asked questions more often (though not as much as I should have), and slowly I began to understand the problems better. My grades gradually got better, by going from a D– to a C+ to a B and eventually I got an A–. It was hard, but that is Exeter. You just have to get passed that first hump, though little ones will follow. As long as you don’t compare yourself to others, and you ask for help when you need it, you should get used to the math curriculum. I still struggle, but as long as I don’t get intimidated and don’t give up, I am able to bring my grades up.

— Charly Simpson ’04

*The above quotes in italics were taken from a survey of new students in the spring of 2001.*

## Mathematics 1

1. Light travels at 186282 miles per second, and the Sun is about 93 million miles from the Earth. How many minutes does it take light to reach the Earth from the Sun?
2. How long would it take you to count nonstop to one billion, if you counted by ones? First, write a guess into your notebook. Now try to solve the problem. One approach is to actually do it and have someone time you. There is another way to approach the problem, however. What do you need to know? What assumptions are you making?
3. It takes 1.25 seconds for light to travel from the Moon to the Earth. How many miles away is the Moon?
4. Many major-league baseball pitchers can throw the ball at 90 miles per hour. At that speed, how long does it take a pitch to travel from the pitcher's mound to home plate, a distance of 60 feet 6 inches? Give your answer to the nearest hundredth of a second. There are 5280 feet in a mile.
5. You have perhaps heard the saying, "A journey of 1000 miles begins with a single step." How many steps would you take to finish a journey of 1000 miles? What information do you need in order to answer this question? Find a reasonable answer. What would your answer be if the journey were 1000 kilometers?
6. In an offshore pipeline, a cylindrical mechanism called a "pig" is run through the pipes periodically to clean them. These pigs travel at 2 feet per second. What is this speed, expressed in miles per hour?
7. Your class sponsors a benefit concert and prices the tickets at \$8 each. Kim sells 12 tickets, Andy 16, Pat 13, and Morgan 17. Compute the total revenue brought in by these four persons. Notice that there are two ways to do the calculation.
8. Kelly telephoned Brook about a homework problem. Kelly said, "Four plus three times two is 14, isn't it?" Brook replied, "No, it's 10." Did someone make a mistake? Can you explain where these two answers came from?
9. It is customary in algebra to omit multiplication symbols whenever possible. For example,  $11x$  means the same thing as  $11 \cdot x$ . Which of the following can be condensed by leaving out a multiplication symbol? (a)  $4 \cdot \frac{1}{3}$  (b)  $1.08 \cdot p$  (c)  $24 \cdot 52$  (d)  $5 \cdot (2 + x)$
10. Wes bought some school supplies at an outlet store in Maine, a state that has a 6.5% sales tax. Including the sales tax, how much did Wes pay for two blazers priced at \$49.95 each and 3 pairs of pants priced at \$17.50 each?
11. (Continuation) A familiar feature of arithmetic is that *multiplication distributes over addition*. Written in algebraic code, this property looks like  $a(b + c) = ab + ac$ . Because of this property, there are two equivalent methods that can be used to compute the answer in the previous problem. Explain, using words and complete sentences.

## Mathematics 1

1. Woolworth's had a going-out-of-business sale. The price of a telephone before the sale was \$39.98. What was the price of the telephone after a 30% discount? If the sale price of the same telephone had been \$23.99, what would the (percentage) discount have been?
2. Pick any number. Add 4 to it and then double your answer. Now subtract 6 from that result and divide your new answer by 2. Write down your answer. Repeat these steps with another number. Continue with a few more numbers, comparing your final answer with your original number. Is there a pattern to your answers?
3. Using the four integers 2, 3, 6 and 8 once each — in any order — and three arithmetic operations selected from among addition, subtraction, multiplication, and division, write expressions whose values are the target numbers given below. You will probably need to use parentheses. For example, to hit the target 90, you could write  $90 = (3 + 6) \cdot (8 + 2)$ .  
(a) 3                      (b) 24                      (c) 36                      (d) 30
4. When describing the growth of a population, the passage of time is sometimes described in generations, a generation being about 30 years. One generation ago, you had two ancestors (your parents). Two generations ago, you had four ancestors (your grandparents). Ninety years ago, you had eight ancestors (your great-grandparents). How many ancestors did you have 300 years ago? 900 years ago? Do your answers make sense?
5. On a recent episode of *Who Wants to Be a Billionaire*, a contestant was asked to arrange the following five numbers in increasing order. You try it, too.  
(a)  $\frac{2}{3}$                       (b) 0.6666                      (c)  $\frac{3}{5}$                       (d) 0.666                      (e) 0.67
6. The area of a circle whose radius is  $r$  is given by the expression  $\pi r^2$ . Find the area of each of the following circles to the nearest tenth of a square unit of measure:  
(a) a circle whose radius is 15 cm                      (b) a circle whose radius is 0.3 miles
7. Choose any number. Double it. Subtract six and add the original number. Now divide by three. Repeat this process with other numbers, until a pattern develops. By using a variable such as  $x$  in place of your number, show that the pattern does not depend on which number you choose initially.
8. Explain why there are two ways to compute each of the following:  
(a)  $3(2 + 3 + 5)$                       (b)  $\frac{1}{3}(9 + 6 - 3)$                       (c)  $(9 + 6 - 3) \div 3$
9. Given the information  $w = 4$  inches and  $h = 7$  inches, find two ways to evaluate  $2w + 2h$ . What is the geometric significance of this calculation?
10. Simplify  $x + 2 + x + 2 + x + 2 + x + 2 + x + 2 + x + 2 + x + 2 + x + 2 + x + 2$ .

## Mathematics 1

1. What is the value of  $3 + (-3)$ ? What is the value of  $(-10.4) + 10.4$ ? These pairs of numbers are called *opposites*. What is the sum of a number and its opposite? Does every number have an opposite? State the opposite of:

- (a)  $-2.341$       (b)  $1/3$       (c)  $x$       (d)  $x + 2$       (e)  $x - 2$

2. As shown on the number line below,  $k$  represents an unknown number between 2 and 3. Plot each of the following, extending the line if necessary:

- (a)  $k + 3$       (b)  $k - 2$       (c)  $-k$       (d)  $6 - k$

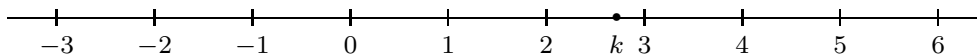

3. You are already familiar with operations involving positive numbers, but much mathematical work deals with negative numbers. Common uses include temperatures, money, and games. It is important to understand how these numbers behave in arithmetic calculations. First, consider addition and subtraction. For each of the following, show how the answer can be visualized using a number-line diagram:

(a) The air temperature at 2 pm was  $12^\circ$ . What was the air temperature at 8 pm, if it had dropped  $15^\circ$  by then?

(b) Telescope Peak in the Panamint Mountain Range, which borders Death Valley, is 11045 feet above sea level. At its lowest point, Death Valley is 282 feet below sea level. What is the vertical distance from the bottom of Death Valley to the top of Telescope Peak?

(c) In a recent game, I had a score of 3. I then proceeded to lose 5 points and 7 points on my next two turns. On the turn after that, however, I gained 8 points. What was my score at this moment in the game?

4. To buy a ticket for a weekly state lottery, a person selects 6 integers from 1 to 36, the order not being important. There are 1947792 such combinations of six digits. Alex and nine friends want to win the lottery by buying every possible ticket (all 1947792 combinations), and plan to spend 16 hours a day doing it. Assume that each person buys one ticket every five seconds. What do you think of this plan? Can the project be completed within a week?

5. Locate the following numbers relative to each other on a number line:

- (a) 3.03      (b) 3.303      (c) 3.033      (d) 3.333      (e) 3.33

6. The area of the surface of a sphere is described by the formula  $S = 4\pi r^2$ , where  $r$  is the radius of the sphere. The Earth has a radius of 3960 miles and dry land forms approximately 29.2% of the Earth's surface. What is the area of the dry land on Earth? What is the surface area of the Earth's water?

7. Mark a random number  $x$  between 1 and 2 (at a spot that only you will think of) on a number line. Plot the *opposite* of each of the following:

- (a)  $x$       (b)  $x + 5$       (c)  $x - 4$       (d)  $6 - x$

## Mathematics 1

1. At 186282 miles per second, how far does light travel in a year? Give your answer in miles, but use *scientific notation*, which expresses a large number like 93400000 as  $9.34 \times 10^7$  (which might appear on your calculator as 9.34 E7 instead). The answer to this question is called a *light year* by astronomers, who use it to measure huge distances. Other than the Sun, the star nearest the Earth is Proxima Centauri, a mere 4.2 light years away.

2. Before you are able to take a bite of your new chocolate bar, a friend comes along and takes  $\frac{1}{4}$  of the bar. Then another friend comes along and you give this person  $\frac{1}{3}$  of what you have left. Make a diagram that shows the part of the bar left for you to eat.

3. Later you have another chocolate bar. This time, after you give away  $\frac{1}{3}$  of the bar, a friend breaks off  $\frac{3}{4}$  of the remaining piece. What part of the original chocolate bar do you have left? Answer this question by drawing a diagram.

4. Profits and losses for the Whirligig Sports Equipment Company for the six years indicated are graphed on the chart at the right. The vertical scale is in millions of dollars. What was the change in profit and losses from

(a) 1993 to 1994?

(b) 1994 to 1995?

(c) 1997 to 1998?

For the six years graphed, did the company make an overall profit or sustain an overall loss? How much was the net change?

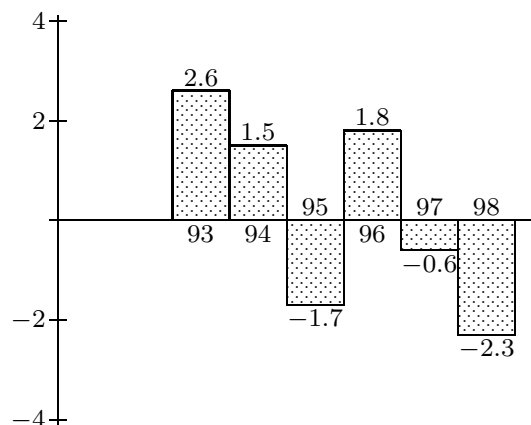

5. The temperature outside is dropping  $3^\circ$  per hour. If the temperature at noon was  $0^\circ$ , what was the temperature at 1 pm? at 2 pm? at 3 pm? at 6 pm? What was the temperature  $t$  hours after noon?

6. The distributive property states that  $(-1)x + 1x$  is the same as  $(-1 + 1)x$ , and this is 0. It follows that  $(-1)x$  is the same as  $-x$ . Explain why, then use similar reasoning to explain why  $(-x)y$  is the same as  $-(xy)$ . By the way, is it correct to say that “ $-x$  is a negative number”?

7. This year, there are 1016 students at the Academy, of whom 63 live in Dunbar Hall. To the nearest tenth of a percent, what part of the student population lives in Dunbar?

8. The product of two negative numbers is always a positive number. How would you explain this rule to a classmate who does not understand why the product of two negative numbers must be positive?

9. Let  $k$  represent some unknown number between  $-4$  and  $-5$ . Locate between two consecutive integers each of the following:

(a)  $-k$

(b)  $-k + 5$

(c)  $\frac{k}{2} + 2$

(d)  $\frac{k + 2}{2}$



## Mathematics 1

1. Use the *balance diagram* below to find how many marbles it takes to balance one cube.

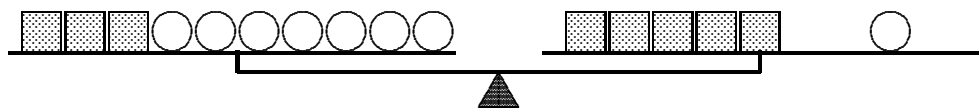

2. (Continuation) Using  $c$  to stand for the weight of one cube and  $m$  for the weight of one marble, write an equation that models the picture in the previous problem. Use this equation to find how many marbles it takes to balance one cube.

3. The division problem  $12 \div \frac{3}{4}$  is equivalent to the multiplication problem  $12 \cdot \frac{4}{3}$ . Write each of the following division problems as equivalent multiplication problems:

(a)  $20 \div 5$       (b)  $20 \div \frac{1}{5}$       (c)  $20 \div \frac{2}{5}$       (d)  $a \div \frac{b}{c}$       (e)  $\frac{b}{c} \div a$

4. What is the value of  $\frac{2}{3} \cdot \frac{3}{2}$ ? What is the value of  $4 \cdot \frac{1}{4}$ ? These pairs of numbers are called *reciprocals*. What is the product of a number and its reciprocal? Does every number have a reciprocal? State the reciprocal of the following:

(a)  $\frac{5}{3}$       (b)  $-\frac{1}{2}$       (c) 2000      (d)  $\frac{a}{b}$       (e)  $x$

5. Here is another number puzzle: Pick a number, add 5 and multiply the result by 4. Add another 5 and multiply the result by 4 again. Subtract 100 from your result and divide your answer by 8. How does your answer compare to the original number? You may need to do a couple of examples like this until you see the pattern. Use a variable for the chosen number and show how the pattern holds for any number.

6. (Continuation) Make up a number puzzle of your own. Be able to verify the pattern using a variable for the number chosen initially.

7. Jess takes a board that is 50 inches long and cuts it into two pieces, one of which is 16 inches longer than the other. How long is each piece?

8. Consider the sequence of numbers 2, 5, 8, 11, 14, ..., in which each number is three more than its predecessor.

(a) Find the next three numbers in the sequence.

(b) Find the  $100^{\text{th}}$  number in the sequence.

(c) Using the variable  $n$  to represent the position of a number in the sequence, write an expression that allows you to calculate the  $n^{\text{th}}$  number. The  $200^{\text{th}}$  number in the sequence is 599. Verify that your expression works by evaluating it with  $n$  equal to 200.

9. A group of ten persons were planning to contribute equal amounts of money to buy some pizza. After the pizza was ordered, one person left. Each of the other nine persons had to pay 60 cents extra as a result. How much was the total bill?

## Mathematics 1

1. In the balance diagram below, find the number of marbles that balance one cube.

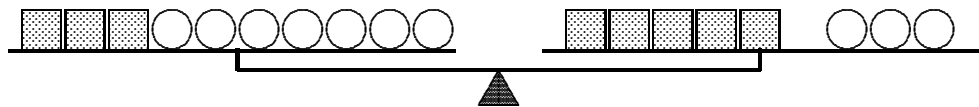

2. For each of the following, find the value of  $x$  that makes the equation true. The usual way of wording this instruction is *solve for  $x$* :

(a)  $2x = 12$

(b)  $-3x = 12$

(c)  $ax = b$

3. On each of the following number lines, all of the labeled points are evenly spaced. Find coordinates for the seven points designated by the letters.

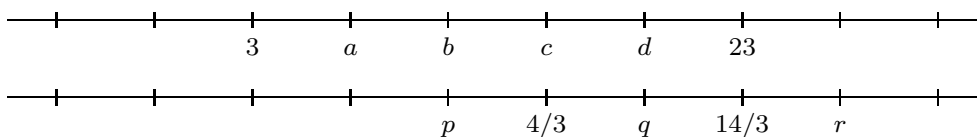

4. Using the four integers 1, 2, 3 and 4 once each — in any order — and three arithmetic operations selected from among addition, subtraction, multiplication, and division, is it possible to write an expression whose value is 1? Using the same numbers and conditions, how many of the integers from 1 to 10 can you form? You will need to use parentheses.

5. A rectangle whose length is  $x$  and whose width is 1 is called an  $x$ -block. The figure shows two of them.

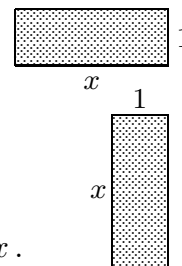

- (a) What is the area of an  $x$ -block?  
 (b) What is the combined area of two  $x$ -blocks?  
 (c) Show that there are two different ways to combine two  $x$ -blocks to form a rectangle whose area is  $2x$ .  
 (d) Draw two different rectangular diagrams to show that  $x + 2x = 3x$ .

6. Use the distributive property to explain why  $3x + 2x$  can be simplified to  $5x$ .

7. (Continuation) Write each of the following as a product of  $x$  and another quantity:

(a)  $16x + 7x$

(b)  $12x - 6x$

(c)  $ax + bx$

(d)  $px - qx$

8. Solve each of the following equations for  $x$ :

(a)  $16x + 7x = 46$

(b)  $12x - 6x = 3$

(c)  $ax + bx = 10$

(d)  $px - qx = r$

9. Draw a balance diagram that is modeled by the equation  $c+m+c+7m+c = 2c+2m+3c$ . How many marbles will one cube balance?

## Mathematics 1

- In baseball statistics, a player's slugging ratio is defined to be  $\frac{s + 2d + 3t + 4h}{b}$ , where  $s$  is the number of singles,  $d$  the number of doubles,  $t$  the number of triples and  $h$  the number of home runs obtained in  $b$  times at bat. Dana came to bat 75 times during the season, and hit 12 singles, 4 doubles, 2 triples, and 8 home runs. What is Dana's slugging ratio, rounded to three decimal places?
- Make a dot somewhere between 0 and 0.5 on a number line, and label it  $k$ . Place each of the following on the same number line as accurately as you can.  
(a)  $-k$                       (b)  $2k$                       (c)  $k^2$                       (d)  $k - 2$                       (e)  $\sqrt{k}$
- Simplify each of the following:  
(a) the sum of  $6x + 2$  and  $-8x + 5$ ;  
(b) the result of subtracting  $5x - 17$  from  $8x + 12$ ;  
(c) the product of  $7x$  and  $4x - 9$ .
- Solve  $\frac{2}{3}(3x + 14) = 7x + 6$ , by first multiplying both sides of the equation by 3, then applying the distributive property to the left side of the equation.
- Because  $12x^2 + 5x^2$  is equivalent to  $17x^2$ , the expressions  $12x^2$  and  $5x^2$  are called *like terms*. Explain. Why are  $12x^2$  and  $5x$  called *unlike terms*? Are  $3ab$  and  $11ab$  like terms? Explain. Are  $12x^2$  and  $5y^2$  like terms? Explain. Are  $12x^2$  and  $12x$  like terms? Explain.
- In each of the following, use appropriate algebraic operations to remove the parentheses and combine like terms. Leave your answers in a simple form.  
(a)  $x(x + 5) + 2(x + 5)$     (b)  $2x(5x - 2) + 3(5x - 2)$     (c)  $5m(3m - 2n) + 4n(3m - 2n)$
- True or false, with justification:  $\frac{7}{12} + \frac{11}{12} + \frac{1}{12} + \frac{19}{12}$  is equivalent to  $\frac{1}{12}(7 + 11 + 1 + 19)$ .
- Jess has just finished telling Lee about learning a wonderful new algebra trick:  $3 + 5x$  can be simplified very neatly to just  $8x$ , because  $a + bx$  is the same as  $(a + b)x$ . Now Lee has to break some bad news to Jess. What is it?
- Find whole numbers  $m$  and  $n$  that fit the equation  $3m + 6n = 87$ . Is it possible to find whole numbers  $m$  and  $n$  that fit the equation  $3m + 6n = 95$ ? If so, find an example. If not, explain why not.
- If  $m$  and  $n$  stand for integers, then  $2m$  and  $2n$  stand for even integers. Explain. Use the distributive property to show that the sum of any two even numbers is even.
- (Continuation) Show that the sum of any two odd numbers is even.
- Solve  $9x + 2 = \frac{3}{4}(2x + 11)$ .

## Mathematics 1

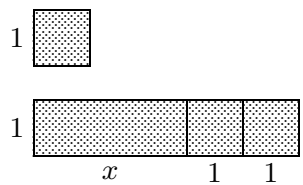
- Jan has a  $18'' \times 18'' \times 12''$  gift box that needs to be placed carefully into a  $2' \times 2' \times 2'$  shipping carton, surrounded by packing peanuts.
  - How many 1-cubic-foot bags of peanuts does Jan need to buy?
  - Jan opens one bag of peanuts and spreads them evenly on the bottom of the shipping carton. What is the resulting depth of the peanuts?
  - Jan centers the square base of the gift box on the peanut layer, pours in another bag of peanuts, and spreads them around evenly. Now how deep are the peanuts?
  - Explain why the third bag of peanuts will cover the gift box.
- Simplify the expression  $k - 2(k - (2 - k)) - 2$  by writing it without using parentheses.
- Coffee beans lose 12.5% of their weight during roasting. In order to obtain 252 kg of roasted coffee beans, how many kg of unroasted beans must be used?
- Last year the price of an iPod was \$240.
  - This year the price increased to \$260. By what percent did the price increase?
  - If the price next year were 5% more than this year's price, what would that price be?
  - If the price dropped 5% the year after that, show that the price would not return to \$260. Explain the apparent paradox.
- During a recent episode of *Who Wants to Be a Billionaire*, your friend Terry called you, needing help with solving the equation  $5x + 1 = 2x + 7$ . Write down the step-by-step instructions you would give Terry over the phone.
- Which number is closer to zero,  $-4/5$  or  $5/4$ ?
- Several Preps were meeting in a room. After 45 of them left, the room was  $5/8$  as full as it was initially. How many Preps were in the room at the start of the meeting?
- The figure shows some more algebra blocks. The 1-by-1 square is called a *unit block*, or a *1-block*. Below the 1-block is a representation of  $x + 2$ , formed from an  $x$ -block and two 1-blocks. Draw a diagram using the appropriate number of  $x$ -blocks and 1-blocks to illustrate the distributive property  $3(x + 2) = 3x + 6$ .
- Often it is necessary to rearrange an equation so that one variable is expressed in terms of others. For example, the equation  $D = 3t$  expresses  $D$  in terms of  $t$ . To express  $t$  in terms of  $D$ , divide both sides of this equation by 3 to obtain  $D/3 = t$ .
  - Solve the equation  $C = 2\pi r$  for  $r$  in terms of  $C$ .
  - Solve the equation  $p = 2w + 2h$  for  $w$  in terms of  $p$  and  $h$ .
  - Solve the equation  $3x - 2y = 6$  for  $y$  in terms of  $x$ .
- On a number line, what number is halfway between (a)  $-4$  and  $11$ ? (b)  $m$  and  $n$ ?

## Mathematics 1

1. Temperature is measured in both Celsius and Fahrenheit degrees. These two systems are of course related: the Fahrenheit temperature is obtained by adding 32 to  $\frac{9}{5}$  of the Celsius temperature. In the following questions, let  $C$  represent the Celsius temperature and  $F$  the Fahrenheit temperature.

- (a) Write an equation that expresses  $F$  in terms of  $C$ .
- (b) Use this equation to find the value of  $F$  that corresponds to  $C = 20$ .
- (c) On the Celsius scale, water freezes at  $0^\circ$  and boils at  $100^\circ$ . Use your formula to find the corresponding temperatures on the Fahrenheit scale. Do you recognize your answers?
- (d) A quick way to get an approximate Fahrenheit temperature from a Celsius temperature is to double the Celsius temperature and add 30. Explain why this is a good approximation. Convert  $23^\circ$  Celsius the quick way. What is the difference between your answer and the correct value? For what Celsius temperature does the quick way give the correct value?

2. You measure your stride and find it to be 27 inches. If you were to walk to Newfields, a town 4.5 miles north of Exeter, how many steps would you have to take? Remember that there are 12 inches in a foot, 3 feet in a yard, and 5280 feet in a mile.

3. The Millers must make a 70-mile Thanksgiving trip to visit their grandparents. Pat Miller believes in driving at a steady rate of 50 miles per hour.

- (a) With Pat in the driver's seat, how much time will the trip take?
- (b) How many miles will the Millers travel in 18 minutes?
- (c) Write an expression for the number of miles they will cover in  $t$  minutes of driving.
- (d) After  $t$  minutes of driving, how many miles remain to be covered?

4. The length of a certain rectangle exceeds its width by exactly 8 cm, and the perimeter of the rectangle is 66 cm. What is the width of the rectangle? Although you may be able to solve this problem using a method of your own, try the following approach, which starts by guessing the width of the rectangle. Study the first row of the table below, which is based on a 10-cm guess for the width. Then make your own guess and use it to fill in the next row of the table. If you have not guessed the correct width, use another row of the table and try again.

<i>guess</i>	<i>length</i>	<i>perimeter</i>	<i>target</i>	<i>check?</i>
10	$10 + 8 = 18$	$2(10) + 2(18) = 56$	66	no

Now use the experience gained by filling in the table to write an equation for the problem: Write  $w$  in the *guess* column, fill in the length and perimeter entries in terms of  $w$ , and set your expression for the perimeter equal to the target perimeter. Solve the resulting equation. This approach to creating equations is called the *guess-and-check* method.

5. Solve for  $x$ :     (a)  $3x - 4 = 11$     (b)  $-2x + 5 = -1$     (c)  $ax + b = c$

## Mathematics 1

1. *Number-line graphs.* Observe the following conventions, which may already be familiar:
- To indicate an interval on the number line, thicken that part of the number line.
  - To indicate that an endpoint of an interval is included, place a solid dot on the number.
  - To indicate that an endpoint is not included, place an open circle on the number.

For example, the diagram illustrates those numbers that are greater than  $-2$  and less than or equal to  $3$ .

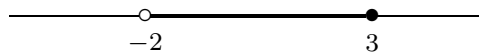

Draw a number line for each of the following and indicate the numbers described:

- (a) All numbers that are exactly two units from 5.  
 (b) All numbers that are more than two units from 5.  
 (c) All numbers that are greater than  $-1$  and less than or equal to  $7$ .  
 (d) All numbers that are less than four units from zero.
2. Percent practice: (a) 25% of 200 is what number? (b) 200 is 25% of what number?  
 (c) Express  $2/25$  as a decimal; as a percent. (d) Express 24% as a decimal; as a fraction.

3. At West Point, the “plebe” (first year cadet) who brings dessert to the table must divide it into pieces that are exactly the size requested by the cadets at the table. One night, the two seniors assigned to the table requested  $1/6$  of the pie and  $1/5$  of the pie, respectively. How much of the pie did that leave for the younger cadets?

4. Ryan earns  $x$  dollars every seven days. Write an expression for how much Ryan earns in one day. Ryan’s spouse Lee is paid twice as much as Ryan. Write an expression for how much Lee earns in one day. Write an expression for their combined daily earnings.

5. Solve for  $x$ :     (a)  $2(x - 3) = 4$     (b)  $-3(2x + 1) = 5$     (c)  $a(bx + c) = d$

6. Day student Avery just bought 10 gallons of gasoline, the amount of fuel used for the last 355 miles of driving. Being a curious sort, Avery wondered how much fuel had been used in city driving (which takes one gallon for every 25 miles) and how much had been used in freeway driving (which takes one gallon for each 40 miles). Avery started by guessing 6 gallons for the city driving, then completed the first row of the guess-and-check table below. Notice the failed check. Make your own guess and use it to fill in the next row of the table.

<i>city g</i>	<i>freeway g</i>	<i>city mi</i>	<i>freeway mi</i>	<i>total mi</i>	<i>target</i>	<i>check</i>
6	$10 - 6 = 4$	$6(25) = 150$	$4(40) = 160$	$150 + 160 = 310$	355	no

Now write  $c$  in the city-gallon column, fill in the remaining entries in terms of  $c$ , and set your expression for the total mileage equal to the target mileage. Solve the resulting equation.

7. On a number line, graph all numbers that are closer to 5 than they are to 8.

## Mathematics 1

1. Atiba walked to a friend's house,  $m$  miles away, at an average rate of 4 mph. The  $m$ -mile walk home was at only 3 mph, however. Express as a fraction  
**(a)** the time Atiba spent walking home;  
**(b)** the total time Atiba spent walking.

2. The sum of four consecutive integers is 2174. What are the integers?

3. (Continuation) The smallest of four consecutive integers is  $n$ . What expression represents the next larger integer? Write an expression for the sum of four consecutive integers, the smallest of which is  $n$ . Write an equation that states that the sum of four consecutive integers is  $s$ . Solve the equation for  $n$  in terms of  $s$ . Check that your answer to the previous question satisfies this equation by considering the case  $s = 2174$ .

4. Solve for  $x$ :      **(a)**  $2(x - 1) = 3(x + 2)$       **(b)**  $-4(2x - 2) = 3(x + 1)$

5. There are three feet in a yard. Find the number of feet in 5 yards. Find the number of yards in 12 feet. Find the number of feet in  $y$  yards. Find the number of yards in  $f$  feet.

6. Sam and Cam have a lawn-mowing service. Their first job tomorrow morning is one that usually takes Sam 40 minutes to do alone, or Cam 30 minutes to do alone. This time they are going to team up, Sam starting at one side and Cam at the other side. The problem is to predict how many minutes it will take them to finish the job. What part of the lawn will Sam complete in the first ten minutes? What part of the lawn will Cam complete in the first ten minutes? What part of the lawn will the team complete in ten minutes? Set up a guess-and-check table with columns titled "minutes", "Sam part", "Cam part" and "Team part". What is the target value for the team part? Fill in two rows of the chart by making guesses in the minutes column. Then guess  $m$  and complete the solution algebraically.

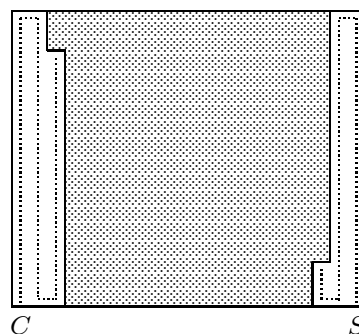

7. Write an expression that represents the number that

- (a)** is 7 more than  $x$ ;      **(b)** is 7 less than  $x$ ;      **(c)** is  $x$  more than 7;  
**(d)** exceeds  $x$  by 7;      **(e)** is  $x$  less than 7;      **(f)** exceeds 7 by  $x$ .

8. The  $x^2$ -block, shown at right, is another member of the algebra-block family. Draw an algebra-block diagram that shows that  $x(x+2) = x^2 + 2x$ .

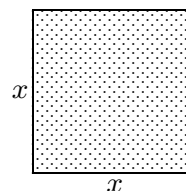

9. There are 396 persons in a theater. If the *ratio* of women to men is 2:3, and the ratio of men to children is 1:2, how many men are in the theater?

10. On a number line, graph a number that is twice as far from 5 as it is from 8. How many such numbers are there?

## Mathematics 1

- Intervals on a number line are often described using the symbols  $<$  (“less than”),  $>$  (“greater than”),  $\leq$  (“less than or equal to”), and  $\geq$  (“greater than or equal to”). As you graph the following inequalities, remember the *endpoint convention* regarding the use of the dot  $\bullet$  and the circle  $\circ$  for included and excluded endpoints, respectively:  
(a)  $x < 5$       (b)  $x \geq -6$       (c)  $-12 \geq x$       (d)  $4 < x < 8$       (e)  $x < -3$  or  $7 \leq x$
- Solve the equation  $A = P + Prt$  for  $r$ . Solve the equation  $A = P + Prt$  for  $P$ .
- Using a number line, describe the location of  $\frac{x+y}{2}$  in relation to the locations of  $x$  and  $y$ . Is your answer affected by knowing whether  $x$  and  $y$  are positive or not?
- Find the smallest positive integer divisible by every positive integer less than or equal to 10.
- Evaluate the formula  $36y + 12f + i$  when  $y = 2.5$ ,  $f = 2$ , and  $i = 5$ . Find an interpretation for this formula.
- The indicator on the oil tank in my home indicated that the tank was one-eighth full. After a truck delivered 240 gallons of oil, the indicator showed that the tank was half full. What is the capacity of the oil tank, in gallons?
- One of the PEA interscholastic teams has started its season badly, winning 1 game, losing 6, and tying none. The team will play a total of 25 games this season.
  - What percentage of the seven games played so far have been wins?
  - Starting with its current record of 1 win and 6 losses, what will the cumulative winning percentage be if the team wins the next 4 games in a row?
  - Starting with its current record of 1 win and 6 losses, how many games in a row must the team win in order for its cumulative winning percentage to reach at least 60%?
  - Suppose that the team wins ten of its remaining 18 games. What is its final winning percentage?
  - How many of the remaining 18 games does the team need to win so that its final winning percentage is at least 60%? Is it possible for the team to have a final winning percentage of 80%? Explain.
- Graph on a number line the intervals described below:
  - All numbers that are greater than 1 or less than  $-3$ .
  - All numbers that are greater than  $-5$  and less than or equal to 4.
  - All numbers whose squares are greater than or equal to 1.
- Use mathematical notation to represent the intervals described below.
  - All numbers that are greater than 1 or less than  $-3$ .
  - All numbers that are greater than  $-5$  and less than or equal to 4.
  - All numbers whose squares are greater than or equal to 1.



## Mathematics 1

1. Randy and Sandy have a total of 20 books between them. After Sandy loses three by leaving them on the bus, and some birthday gifts double Randy's collection, their total increases to 30 books. How many books did each have before these changes?

2. Combine the following fractions into a single fraction. Express each of your answers in lowest terms.

(a)  $\frac{27}{5} + \frac{3y}{4}$       (b)  $\frac{4m}{5} - \frac{2}{3}$       (c)  $2 + \frac{x}{3}$       (d)  $\frac{x}{2} + \frac{2x}{3} - \frac{3x}{4}$

3. Solve the following for  $x$ :

(a)  $4 - (x + 3) = 8 - 5(2x - 3)$       (b)  $x - 2(3 - x) = 2x + 3(1 - x)$

4. *Guessing birthdays.* Pat is working a number trick on Kim, whose birthday is the 29<sup>th</sup> of February. The table below shows the sequence of questions that Pat asks, as well as the calculations that Kim makes in response. Another column is provided for the algebra you are going to do to solve the trick. Use the letters  $m$  and  $d$  for month and day.

<i>Instruction</i>	<i>Kim</i>	<i>Algebra</i>
Write the number of your birthmonth	2	$m$
Multiply by 5	10	
Add 7	17	
Multiply by 4	68	
Add 13	81	
Multiply by 5	405	
Add the day of the month of your birthday	434	

After hearing the result of the last calculation, Pat can do a simple mental calculation and then state Kim's birthday. Explain how. To test your understanding of this trick, try it on someone whose birthday is unknown to you.

5. Last year, three fifths of the Outing Club were girls, but this year the number of boys doubled and six new girls joined. There are now as many boys in the club as there are girls. How many members did the club have last year?

6. I am thinking of  $n$  consecutive positive integers, the smallest of which is  $m$ . What formula represents the largest of these integers?

7. The base of a rectangular tank is three feet by two feet, and the tank is three feet tall. The water in the tank is currently just nine inches deep.

(a) The water level will rise when a one-foot metal cube (denser than water) is placed on the bottom of the tank. By how much?

(b) The water level will rise some more when a second one-foot metal cube is placed on the bottom of the tank, next to the first one. By how much?

8. Place a common mathematical symbol between the numerals 2 and 3, so as to produce a number that lies between 2 and 3 on a number line.

# Mathematics 1

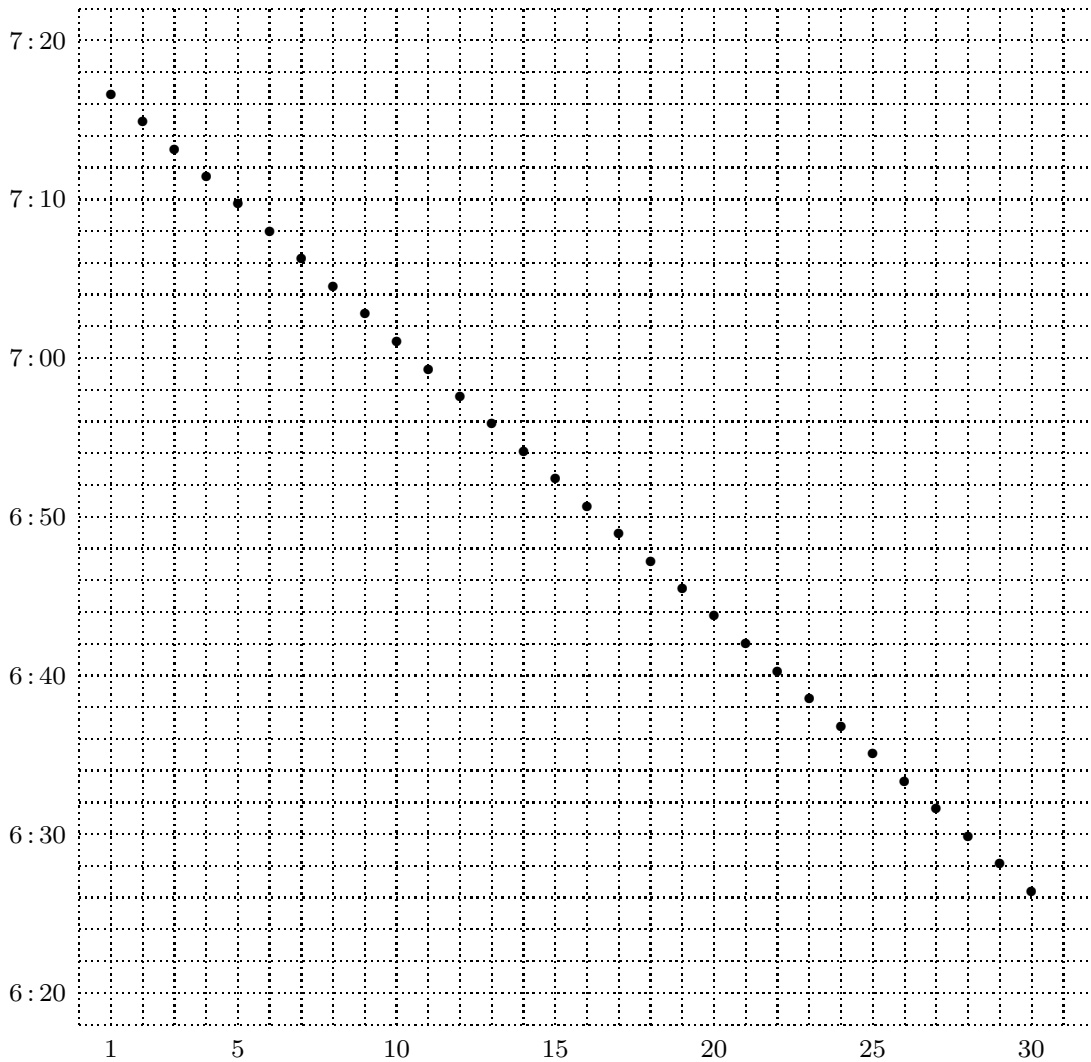

The graph displays the time of sunset at Exeter during September. Some questions:

1. At what time did the sun set on the 5<sup>th</sup> of September? on the 30<sup>th</sup> of September?
2. On what day does the sun set at 6:54? at 7:08? at 6:30?
3. Guess the time of sunset on the 1<sup>st</sup> of October and on the 31<sup>st</sup> of August.
4. What is the average daily change of sunset time during the month of September?
5. The dots in the graph form a pattern. Jess thinks that this pattern continues into October, November, and December. What do you think? Make a graph that shows how the time of sunset at Exeter changes during an entire year. A good source for such data is the U.S. Naval Observatory site <http://aa.usno.navy.mil>.
6. What happens on the Autumnal Equinox, which is the 22<sup>nd</sup> of September? Guess what time the sun rises on this day.

## Mathematics 1

1. A flat, rectangular board is built by gluing together a number of square pieces of the same size. The board is  $m$  squares wide and  $n$  squares long. Using the letters  $m$  and  $n$ , write expressions for

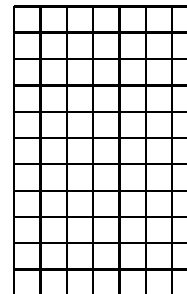

- (a) the total number of  $1 \times 1$  squares;
- (b) the total number of  $1 \times 1$  squares with free edges (the number of  $1 \times 1$  squares that are not completely surrounded by other squares);
- (c) the number of completely surrounded  $1 \times 1$  squares;
- (d) the perimeter of the figure.

2. Graph on a number line the intervals corresponding to these two signs on the highway.

- (a) The maximum speed is 65 mph and the minimum speed is 45 mph.
- (b) The maximum speed is 55 mph.

3. Label the figure at right so that it provides a geometric representation of  $x(x + 3)$ . Notice that this question is about *area*.

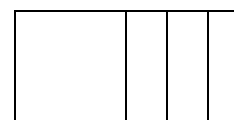

4. It is sometimes necessary to write fractions with variables in the denominator. Without using your calculator, rewrite each of the following as a single fraction. This is called *combining over a common denominator*.

- (a)  $\frac{3}{a} + \frac{7}{a}$
- (b)  $\frac{3}{a} + \frac{7}{2a}$
- (c)  $\frac{3}{a} + \frac{7}{b}$
- (d)  $3 + \frac{7}{b}$

5. It takes one minute to fill a four-gallon container at the Exeter spring. How long does it take to fill a six-gallon container? Fill in the missing entries in the table below, and plot points on the grid at right.

<i>time</i>	1		2		3		4		5
<i>volume</i>	4	5	6		11		14		19

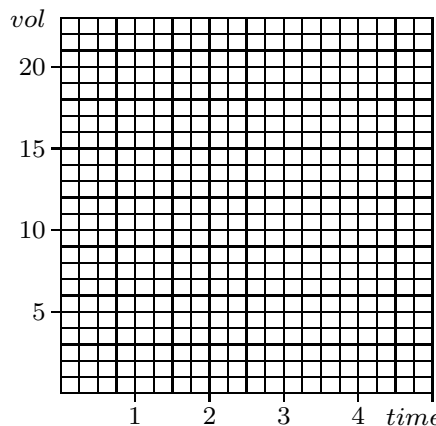

Notice that it makes sense to connect the dots you plotted (thereby forming a continuous pattern). Is the same true of the sunset-time graph you looked at recently? Explain.

6. Ryan took 25 minutes to type the final draft of a 1200-word English paper. How much time should Ryan expect to spend typing the final draft of a 4000-word History paper?

7. Which of the following eight expressions does not belong in the list?

$a - b + c$     $c - b + a$     $c - (b - a)$     $-b + a + c$     $c + a - b$     $a - (b - c)$     $b - (c - a)$     $a + c - b$

8. Last week, Chris bought a DVD for \$10.80 while the store was having a 25%-off sale. The sale is now over. How much would the same DVD cost today?

## Mathematics 1

1. The statement “ $x$  is between 13 and 23” defines an interval using two simultaneous inequalities:  $13 < x$  and  $x < 23$ . The statement “ $x$  is not between 13 and 23” also uses two inequalities, but they are *non-simultaneous*:  $x \leq 13$  or  $23 \leq x$ . Graph these two examples on a number line. Notice that there is a compact form  $13 < x < 23$  for only one of them.

2. Crossing a long stretch of the Canadian plains, passenger trains maintain a steady speed of 80 mph. At that speed, what distance is covered in half an hour? How much time is needed to cover 200 miles? Fill in the missing entries in the table below, and plot points on the grid at right.

<i>time</i>	0	1/2		1	2		3		4	$t$
<i>distance</i>			60			200		300		

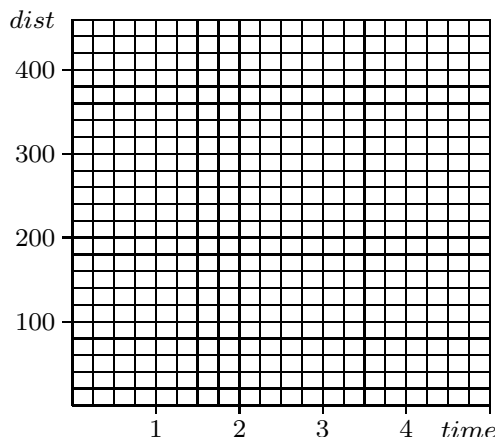

3. The problems about the Exeter spring and the Canadian plains contain relationships that are called *direct variations*. In your own words, describe what it means for one quantity to *vary directly* with another. Which of the following describe direct variations?

- (a) The gallons of water in a tub and the number of minutes since the tap was opened.
- (b) The height of a ball and the number of seconds since it was thrown.
- (c) The length of a side of a square and the perimeter of the square.
- (d) The length of a side of a square and the area of the square.

4. (Continuation) Sketch graphs for each of the situations described above. Be sure to include meaningful descriptions and scales for each axis.

5. Atiba walked to a friend’s house,  $m$  miles away, at an average rate of 4 mph. The  $m$ -mile walk home was only at 3 mph. Atiba spent 2 hours walking in all. Find the value of  $m$ .

6. The sides of a rectangle in the coordinate plane are parallel to the axes. Two of the vertices of the rectangle are  $(3, -2)$  and  $(-4, -7)$ . Find coordinates for the other two vertices. Find the area of the rectangle.

7. The rectangle shown at right has been broken into four smaller rectangles. The areas of three of the smaller rectangles are shown in the diagram. Find the area of the fourth one.

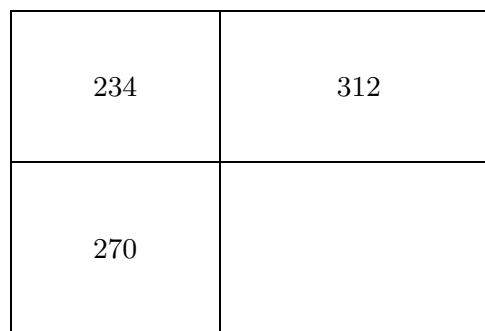

8. Tickets to a school play cost \$1.50 if bought in advance, and \$2.00 if bought at the door. By selling all 200 of their tickets, the players brought in \$360. How many of the tickets were sold in advance?

## Mathematics 1

1. Chandler was given \$75 for a birthday present. This present, along with earnings from a summer job, is being set aside for a mountain bike. The job pays \$6 per hour, and the bike costs \$345. To be able to buy the bike, how many hours does Chandler need to work?
2. (Continuation) Let  $h$  be the number of hours that Chandler works. What quantity is represented by the expression  $6h$ ? What quantity is represented by the expression  $6h + 75$ ?
  - (a) Graph the solutions to the inequality  $6h + 75 \geq 345$  on a number line.
  - (b) Graph the solutions to the inequality  $6h + 75 < 345$  on a number line.What do the solutions to the inequality  $6h + 75 \geq 345$  signify?

3. Sandy recently made a 210-mile car trip, starting from home at noon. The graph at right shows how Sandy's distance from home (measured in miles) depends on the number of hours after noon. Make up a story that accounts for the four distinct parts of the graph. In particular, identify the speed at which Sandy spent most of the afternoon driving.

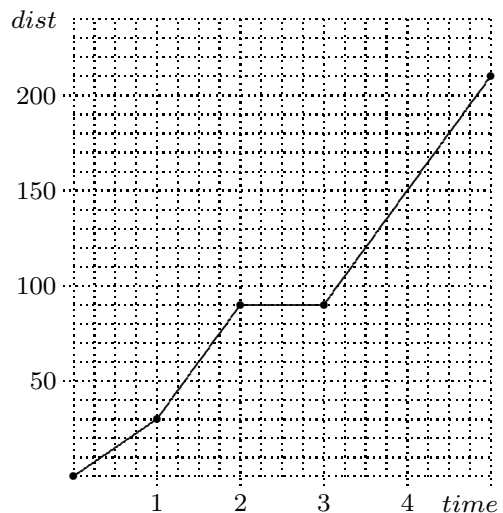

4. Chase began a number puzzle with the words "Pick a number, add 7 to it, and double the result." Chase meant to say, "Pick a number, double it, and add 7 to the result." Are these two instructions equivalent? Explain.
5. The distance from PEA to the beach at Little Boar's Head is 10 miles. If you bike from PEA to the beach in 40 minutes, what is your *average speed* for the trip? What does this mean?
6. (Continuation) On the return trip from the beach, you pedal hard for the first ten minutes and cover 4 miles. Tired, you slow down and cover the last 6 miles in 36 minutes. What is your average speed for the return trip?
7. Solve the inequality  $3 - x > 5$  using only the operations of addition and subtraction. Is  $x = 0$  a solution to the inequality?
8. Alden paid to have some programs printed for the football game last weekend. The printing cost per program was 54 cents, and the plan was to sell them for 75 cents each. Poor weather kept many fans away from the game, however, so unlucky Alden was left with 100 unsold copies, and lost \$12 on the venture. How many programs did Alden have printed?
9. The Mount Major hike starts in Alton Bay, 716 feet above sea level. The summit is 1796 feet above sea level, and it takes about 45 minutes for a typical hiker to make the climb. Find the rate at which this hiker gains altitude, in feet per minute.

## Mathematics 1

1. To do a college visit, Wes must make a 240-mile trip by car. The time required to complete the trip depends on the speed at which Wes drives, of course, as the table below shows. Fill in the missing entries, and plot points on the grid provided. Do the quantities time and speed vary directly? It makes sense to connect your plotted points with a continuous graph. Explain why.

<i>speed</i>	15	20	25			48		60		<i>r</i>
<i>time</i>		12		8	6		4.8		3	

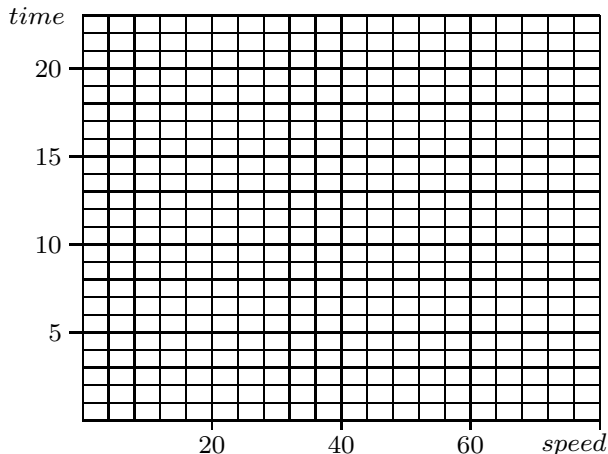

2. Pat bought several pens at Walgreen's, for 60 cents each. Spending the same amount of money at the Bookstore, Pat then bought a few more pens that cost 80 cents each. In all, 42 pens were bought. How many pens did Pat buy at the bookstore?

3. Exeter building code does not permit building a house that is more than 35 feet tall. An architect working on the design shown at right would like the roof to be sloped so that it rises 10 inches for each foot of horizontal run.

(a) Given the other dimensions in the diagram, will the builder be allowed to carry out this plan?

(b) Two vertical supports (shown dotted in the diagram) are to be placed 6 feet from the center of the building. How long should they be?

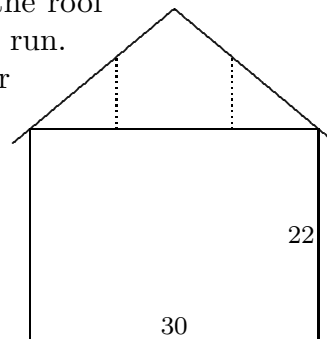

4. The line through  $(1, 6)$  and  $(0, 3)$  passes through every quadrant except one. Which one?

5. Combine over a common denominator without using a calculator:

(a)  $\frac{1}{4} + \frac{1}{5}$                       (b)  $\frac{1}{10} + \frac{1}{11}$                       (c)  $\frac{1}{x} + \frac{1}{x+1}$

Evaluate your answer to (c) with  $x = 4$  and then with  $x = 10$ . How do these answers compare to your answers to (a) and (b)?

6. A small pool is 20 feet long, 12 feet wide and 4 feet deep. There are 7.5 gallons of water in every cubic foot. At the rate of 5 gallons per minute, how long will it take to fill this pool?

7. Shown at right, the  $y$ -block and  $xy$ -block are two more members of the algebra-block family. Draw an algebra-block diagram that illustrates the equation  $(1 + x)y = y + xy$ .

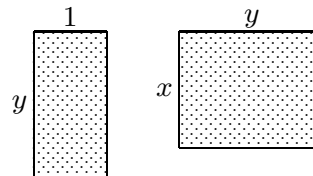

## Mathematics 1

1. The rectangle  $ABCD$  shown at right has sides that are parallel to the coordinate axes. It is three times as wide as it is tall, and its perimeter is 56 units.

(a) Find the length and width of  $ABCD$ .

(b) Given the information  $D = (9, 2)$ , find the coordinates for points  $A$ ,  $B$ , and  $C$ .

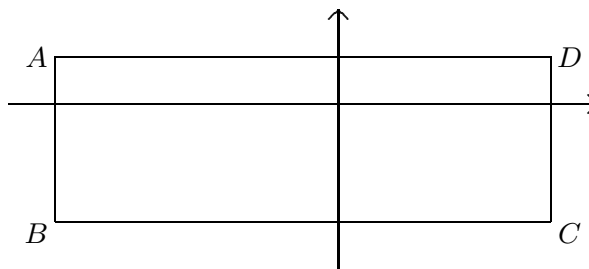

2. A ladder is leaning against the side of a building. Each time I step from one rung to the next, my foot moves 6 inches closer to the building and 8 inches further from the ground. The base of the ladder is 9 ft from the wall. How far up the wall does the ladder reach?

3. Each step of the stairs leading from room 9 to room 107 in the Academy Building has a vertical *rise* of 7 inches and a horizontal *run* of 12 inches. Each step of the marble staircase leading to the Assembly Hall has a vertical rise of 5.5 inches and a horizontal run of 13 inches.

(a) Which flight of stairs do you think is steeper? Why?

(b) Calculate the ratio *rise/run* for each flight of stairs, and verify that the greater ratio belongs to the flight you thought to be steeper.

4. (Continuation) The *slope* of a line is a measure of how steep the line is. It is calculated by dividing the change in  $y$ -coordinates by the corresponding change in  $x$ -coordinates between two points on the line:  $\text{slope} = \frac{\text{change in } y}{\text{change in } x}$ . Calculate the slope of the line that goes through the two points  $(1, 3)$  and  $(7, 6)$ . Calculate the slope of the line that goes through the two points  $(0, 0)$  and  $(9, 6)$ . Which line is steeper?

5. Explain why the descriptions “right 5 up 2”, “right 10 up 4”, “left 5 down 2”, “right  $5/2$  up 1”, and “left 1 down  $2/5$ ” all describe the same inclination for a straight line.

6. At noon one day, the Exeter River peaked at 11 feet above flood stage. It then began to recede, its depth dropping at 4 inches per hour.

(a) At 3:30 that afternoon, how many inches above flood stage was the river?

(b) Let  $t$  stand for the number of hours since noon, and  $h$  stand for the corresponding number of inches that the river was above flood stage. Make a table of values, and write an equation that expresses  $h$  in terms of  $t$ .

(c) Plot  $h$  versus  $t$ , with  $t$  on the horizontal axis.

(d) For how many hours past noon was the river at least 36 inches above flood stage?

7. Solve the following for  $x$ : (a)  $\frac{x}{2} + \frac{x}{5} = 6$  (b)  $\frac{x}{3} + \frac{x+1}{6} = 4$

8. A sign placed at the top of a hill on Route 89 says “8% grade. Trucks use lower gear.” What do you think that “8% grade” might mean?

## Mathematics 1

1. Jess and Taylor go into the cookie-making business. The chart shows how many dozens of cookies were baked and sold (at \$3.50 per dozen) during the first six days of business.

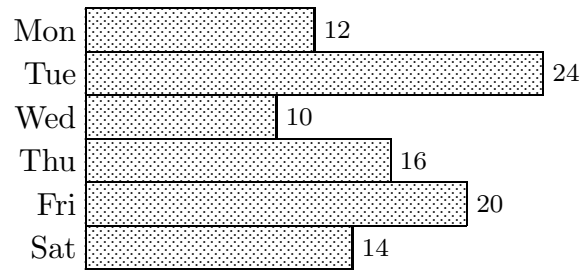

(a) What was their total income during those six days?

(b) Which was more profitable, the first three days or the last three days?

(c) What was the percentage decrease in sales from Tuesday to Wednesday? What was the percentage increase in sales from Wednesday to Thursday?

(d) Thursday's sales were what percent of the total sales?

(e) On average, how many dozens of cookies did Jess and Taylor bake and sell each day?

2. The perimeter of a rectangle is 100 and its length is  $x$ . What expression represents the width of the rectangle?

3. When a third of a number is subtracted from a half of the same number, 60 is the result. Find the number.

4. Suppose that  $n$  represents an integer. What expression represents the next larger integer? the previous integer? the sum of these three consecutive integers?

5. Pat and Kim are solving the inequality  $132 - 4x \leq 36$ . Each begins by subtracting 132 from both sides to get  $-4x \leq -96$ , and then each divides both sides by  $-4$ . Pat gets  $x \leq 24$  and Kim gets  $x \geq 24$ , however. Always happy to offer advice, Alex now suggests to Pat and Kim that answers to inequalities can often be checked by substituting  $x = 0$  into both the original inequality and the answer. What do you think of this advice? Graph each of these answers on a number line. How do the results of this question relate to the flooding of the Exeter River?

6. (Continuation) After hearing Alex's suggestion about using a test value to check an inequality, Wes suggests that the problem could have been done by solving the equation  $132 - 4x = 36$  first. Complete the reasoning behind this strategy.

7. (Continuation) Deniz, who has been keeping quiet during the discussion, remarks, "The only really tricky thing about inequalities is when you try to multiply them or divide them by negative numbers, but this kind of step can be avoided altogether. Wes just told us one way to avoid it, and there is another way, too." Explain this remark by Deniz.

8. Draw the segment from  $(3, 1)$  to  $(5, 6)$ , and the segment from  $(0, 5)$  to  $(2, 0)$ . Calculate their slopes. You should notice that the segments are equally steep, and yet they differ in a significant way. Do your slope calculations reflect this difference?

9. Solve the following inequality for  $x$ :  $2(1 - 3x) - (x - 5) > 1$



## Mathematics 1

1. The volume of blood pumped by your heart each minute varies directly with your pulse rate. Each heartbeat pumps approximately 0.006 liter of blood.

- (a) If your heart beats 50 times a minute, how much blood is pumped in one minute?  
 (b) If your heart pumps 0.45 liters per minute, what is your pulse rate in beats per minute?

2. (Continuation) Direct-variation equations can be written in the form  $y = kx$ . In this equation, we say  $y$  depends on  $x$ . Is it more natural to say that the volume of blood being pumped depends on your heart rate, or that your heart rate depends on the volume of blood being pumped? Find an equation that relates the volume  $v$  and the rate  $r$ . Graph this equation, using an appropriate scale, and calculate its slope. What does the slope represent in this context?

3. Estimate the slopes of all the segments in the diagram. Identify those whose slopes are negative. Find words to characterize lines that have negative slopes.

4. Find the slope of the line containing the points  $(4, 7)$  and  $(6, 11)$ . Find coordinates for another point that lies on the same line and be prepared to discuss the method you used to find them.

5. Find an easy way to do the following calculations mentally: (a)  $25 \cdot 39 \cdot 4$       (b)  $\frac{632}{50}$

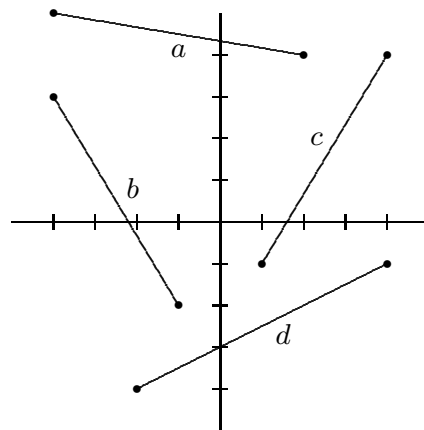

6. To earn Hall of Fame distinction at PEA, a girl on the cross-country team must run the 5-km course in less than 20 minutes. What is the average speed of a 20-minute runner, in km per hour? in meters per second? Express your answers to two decimal places.

7. (Continuation) The proportion  $\frac{5}{20} = \frac{x}{60}$  is helpful for the previous question. Explain this proportion, and assign units to all four of its members.

8. The diagram shows the last member of the algebra-block family, the  $y^2$ -block. Show how an  $xy$ -block and a  $y^2$ -block can be combined to illustrate the equation  $(x + y)y = xy + y^2$ .

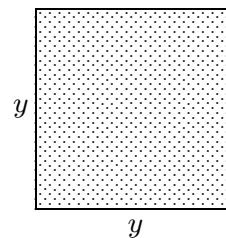

9. Which is greater, 73 percent of 87, or 87 percent of 73?

10. Corey deposits \$300 in a bank that pays 4% annual interest. How much interest does Corey earn in one year? What would the interest be if the rate were 6%?

11. Alex was hired to unpack and clean 576 very small items of glassware, at five cents per piece successfully unpacked. For every item broken during the process, however, Alex had to pay \$1.98. At the end of the job, Alex received \$22.71. How many items did Alex break?

## Mathematics 1

1. Each of the data sets at right represents points on a line. In which table is one variable directly related to the other? Why does the other table not represent a direct variation? Fill in the missing entry in each table.

$x$	$y$
0	4
4	10
10	19
16	

$x$	$y$
0	0
4	6
10	15
16	

2. (Continuation) Plot the data from the tables in the previous question on the same set of axes and use a ruler to draw a line through each set of points. By looking at the graph, how could you recognize the direct variation? What similarities and differences are there between the two lines drawn?

3. Suppose that  $n$  represents a positive even integer. What expression represents the next even integer? the next odd integer? I am thinking of three consecutive even integers, whose sum is 204. What are they?

4. A car and a small truck started out from Exeter at 8:00 am. Their distances from Exeter, recorded at hourly intervals, are recorded in the tables at right. Plot this information on the same set of axes and draw two lines connecting the points in each set of data. What is the slope of each line? What is the meaning of these slopes in the context of this problem?

<i>time</i>	<i>car</i>	<i>truck</i>
8 : 00	0	0
9 : 00	52	46
10 : 00	104	92
11 : 00	156	138
12 : 00	208	184

5. (Continuation) Let  $t$  be the number of hours each vehicle has been traveling since 8:00 am (thus  $t = 0$  means 8:00 am), and let  $d$  be the number of miles traveled after  $t$  hours. For each vehicle, write an equation relating  $d$  and  $t$ .

6. Day student Chris does a lot of babysitting. When parents drop off their children and Chris can supervise at home, the hourly rate is \$3. If Chris has to travel to the child's home, there is a fixed charge of \$5 for transportation in addition to the \$3 hourly rate.

(a) Graph  $y = 3x$  and  $y = 3x + 5$ . What do these lines have to do with the babysitting context? What feature do they have in common? How do they differ?

(b) Predict what the graph of  $y = 3x + 6$  will look like. What change in the babysitting context does this line suggest?

7. If  $k$  stands for an integer, then is it possible for  $k^2 + k$  to stand for an odd integer? Explain.

8. Can you think of a number  $k$  for which  $k^2 < k$  is true? Graph all such numbers on a number line. Also describe them using words, and using algebraic notation.

9. One year after Robin deposits 400 dollars in a savings account that pays  $r\%$  annual interest, how much money is in the account? Write an expression using the variable  $r$ .

10. Solve  $\frac{x}{4} + \frac{x+1}{3} \leq \frac{1}{2}$  and shade the solution interval on a number line.

## Mathematics 1

1. How much time does it take for a jet to go 119 miles, if its speed is 420 mph? Be sure to specify the units for your answer.
2. Find three consecutive odd numbers whose sum is 117. Think of two ways to do this problem.
3. *Word chains.* As the ancient alchemists hoped, it is possible to turn *lead* into *gold*. You change one letter at a time, always spelling real words: lead—load—toad—told—gold. Using the same technique, show how to turn *work* into *play*.
4. Find coordinates for the points where the line  $3x + 2y = 12$  intersects the  $x$ -axis and the  $y$ -axis. These points are called the  $x$ -intercept and  $y$ -intercept, respectively.
5. Drivers in distress near Exeter have two towing services to choose from: Brook's Body Shop charges \$3 per mile for the towing, and a fixed \$25 charge regardless of the length of the tow. Morgan Motors charges a flat \$5 per mile. On the same system of axes, represent each of these choices by a linear graph that plots the cost of the tow versus the length of the tow. If you needed to be towed, which service would you call, and why?
6. Predict what a graph of
  - (a)  $y = 2x + 5$
  - (b)  $y = 3x + 5$will look like. In each case, confirm your prediction on the calculator, and describe a context from which the equation might emerge.
  - (c) Linear equations that look like  $y = mx + b$  are said to be in *slope-intercept form*. Explain. The terminology refers to which of the two intercepts?
7. Driving from Boston to New York one day, Sasha covered the 250 miles in five hours. Because of heavy traffic, the 250-mile return took six hours and fifteen minutes. Calculate average speeds for the trip *to* New York, the trip *from* New York, and the round trip. Explain why the terminology *average speed* is a bit misleading.
8. Find the value of  $x$  that makes  $0.1x + 0.25(102 - x) = 17.10$  true.
9. So that it will be handy for paying tolls and parking meters, Lee puts pocket change (dimes and quarters only) into a cup attached to the dashboard. There are currently 102 coins in the cup, and their monetary value is \$17.10. How many of the coins are dimes?
10. Find all the values of  $x$  that make  $0.1x + 0.25(102 - x) < 17.10$  true.
11. Without using parentheses, write an expression equivalent to  $3(4(3x - 6) - 2(2x + 1))$ .
12. One year after Robin deposits  $P$  dollars in a savings account that pays  $r\%$  annual interest, how much money is in the account? Write an expression in terms of the variables  $P$  and  $r$ . If you can, write your answer using just a single  $P$ .

## Mathematics 1

1. Day student Morgan left home at 7:00 one morning, determined to make the ten-mile trip to PEA on bicycle for a change. Soon thereafter, a parent noticed forgotten math homework on the kitchen table, got into the family car, and tried to catch up with the forgetful child. Morgan had a fifteen-minute head start, and was pedaling at 12 mph, while the parent pursued at 30 mph. Was Morgan reunited with the homework before reaching PEA that day? If so, where? If not, at what time during first period (math, which starts at 8:00) was the homework delivered?

2. Farmer MacGregor needs to put a fence around a rectangular carrot patch that is one and a half times as long as it is wide. The project uses 110 feet of fencing. How wide is the garden?

3. Combine over a common denominator:  $\frac{1}{a} + \frac{2}{3a} + 3$

4. Confirm that the five points in the table all lie on a single line. Write an equation for that line. Use your calculator to make a *scatter plot*, and graph the line on the same system of axes.

$x$	$y$
-3	7
-2	5
-1	3
0	1
1	-1

5. If 6% of  $x$  is the same as 5% of 120, then what is  $x$ ?

6. Find and graph the solution sets for the related questions:

(a)  $46 - 3(x + 10) = 5x + 20$  (b)  $46 - 3(x + 10) < 5x + 20$  (c)  $46 - 3(x + 10) > 5x + 20$

7. At 1 pm, you start out on your bike at 12 mph to meet a friend who lives 8 miles away. At the same time, the friend starts walking toward you at 4 mph. How much time will elapse before you meet your friend? How far will your friend have to walk?

8. The population of a small town increased 25% two years ago and then decreased by 25% last year. The population is now 4500 persons. What was the population before the two changes?

9. Given that it costs \$2.75 less to buy a dozen doughnuts than to buy twelve single doughnuts, and that 65 doughnuts cost \$25.25, and that  $65 = 5 \cdot 12 + 5$ , what is the price of a single doughnut?

10. The volume of a circular cylinder is given by the formula  $V = \pi r^2 h$ .

(a) To the nearest tenth of a cm, find the volume of a cylinder that has a 15-cm radius and is 12 cm high.

(b) Solve the volume formula for  $h$ , and then find  $h$  to the nearest tenth of a cm if the volume is 1000 cc and the radius is 10 cm.

11. It takes ten Preps ten days to paint ten houses. How many houses can five Preps paint in five days?

## Mathematics 1

- Which of the following pairs of quantities vary directly?
  - the circumference of a circle and the diameter of the circle;
  - the distance traveled in two hours and the (average) rate of travel;
  - the number of gallons of gasoline bought and the cost of the purchase;
  - the area of a circle and the radius of the circle.
- A jet, cruising at 26400 feet, begins its descent into Logan Airport, which is 48 miles away. Another jet, cruising at 31680 feet, is 60 miles from Logan when it begins its descent. Which of these two paths of descent is steeper? Explain.
- When it is eighty miles west of its destination, a jet is flying at 31680 feet. When it is forty miles west of its destination, the jet is at 11560 feet. Using this data, sketch a graph of the jet's descent. Is a linear model reasonable to use in this situation? Explain.
- The diagram shows two steel rods hinged at one end. The other end is connected by a bungee cord (the dotted segment), whose unstretched length is 10 inches. The rods are 5 inches and 18 inches long. Use inequality symbols to describe all the possible lengths for the bungee cord, which stays attached at both ends while it is being stretched.

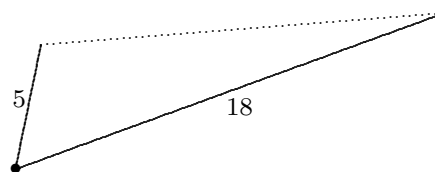

- According to the US Census Department, someone born in 1950 has a life expectancy of 68.2 years, while someone born in 1970 has a life expectancy of 70.8 years.
  - What is a reasonable life expectancy of someone born in 1960?
  - What is a reasonable life expectancy of someone born in 1980?
  - What is a reasonable life expectancy of someone born in 2000?Part (a) is an *interpolation* question. Parts (b) and (c) are *extrapolation* questions. Which of your answers are you the most confident about? Explain.
- Multiply  $2 + x$  by  $2x$ . Draw an algebra-block diagram to illustrate this calculation.
- For each of the following situations, draw a plausible graph that shows the relationship between the time elapsed (horizontal axis) and the indicated speed (vertical axis). In other words, graph speed versus time for each of the following:
  - A car in a bumper test travels at a steady speed until it crashes into a wall.
  - Your workout consists of some jogging, some hard running, some more jogging, some more hard running, and finally some walking.
  - A roller coaster slowly climbs up a steep ramp and then zooms down the other side. (Plot the car's speed just to the bottom of the first hill.)
  - A car speeds at a steady rate along a highway until an officer pulls it over and gives the driver a ticket. The car then resumes its journey at a more responsible speed.
- Solve the following inequalities and shade their solution intervals on a number line.
  - $\frac{2x}{3} + \frac{3x+5}{2} \leq 5$
  - $\frac{1}{2}(x-1) + 3 > \frac{1}{3}(2x+1) - 1$

## Mathematics 1

1. A square game board is divided into smaller squares, which are colored red and black as on a checkerboard. All four corner squares are black. Let  $r$  and  $b$  stand for the numbers of red and black squares, respectively. What is the value of the expression  $b - r$ ?

2. At noon, my odometer read 6852 miles. At 3:30 pm, it read 7034 miles.

(a) What was my average rate of change during these three and a half hours?

(b) Let  $t$  represent the number of hours I have been driving since noon and  $y$  represent my odometer reading. Write an equation that relates  $y$  and  $t$ . Assume constant speed.

(c) Graph your equation.

(d) Show that the point  $(5, 7112)$  is on your line, and then interpret this point in the context of this problem.

3. What is the slope between  $(3, 7)$  and  $(5, 4)$ ?  $(5, 4)$  and  $(3, 7)$ ?  $(a, b)$  and  $(c, d)$ ?  $(c, d)$  and  $(a, b)$ ?

4. Avery's long-distance phone company charges a connect fee in addition to a per-minute charge for each call. Avery's most recent bill included a \$4.24 charge for a 12-minute call and a \$6.00 charge for a 20-minute call.

(a) What is the per-minute charge?

(b) What is the connect fee?

(c) How much would Avery be billed for a five-minute call?

(d) How much would Avery be charged for a call  $m$  minutes long?

(e) Avery was able to figure out answers to (a) and (b) without doing any algebra. How?

5. (Continuation) I was recently called by a telemarketer asking me to change my long-distance phone company. This new company charges \$0.33 per minute with no connect fee. Is this a better deal than the company described in the previous problem? Show evidence.

6. For what values of  $x$  will the square and the rectangle shown at right have the same perimeter?

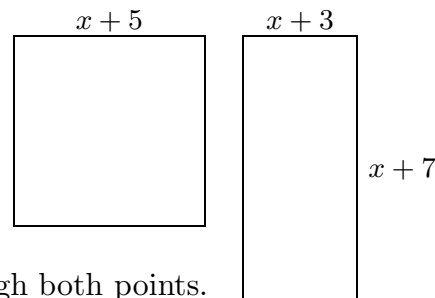

7. The point  $(3, 2)$  is on the line  $y = 2x + b$ . Find the value of  $b$ . Graph the line.

8. Are  $(2, 9)$  and  $(-3, -6)$  both on the line  $y = 4x + 6$ ?

If not, find an equation for the line that does pass through both points.

9. After you graph the line  $y = 4x + 6$ , find

(a) the  $y$ -coordinate of the point on the line whose  $x$ -coordinate is 2;

(b) the  $x$ -coordinate of the point on the line whose  $y$ -coordinate is 2.

10. In each of the following, describe the rate of change between the first pair and the second, assuming that the first coordinate is measured in minutes and the second coordinate is measured in feet. What are the units of your answer?

(a)  $(2, 5)$  and  $(5, 17)$

(b)  $(3.4, 6.8)$  and  $(7.2, 8.7)$

(c)  $\left(\frac{3}{2}, -\frac{3}{4}\right)$  and  $\left(\frac{1}{4}, 2\right)$

## Mathematics 1

1. If you double all the sides of a square, a larger square results. By what percentage has the perimeter increased? By what percentage has the area increased?
2. Given the five numbers  $8/25$ ,  $13/40$ ,  $19/60$ ,  $33/100$ , and  $59/180$ , find the two that are closest together on a number line, and find the distance between them.
3. Find the  $x$ -intercept and the  $y$ -intercept of the equation  $y = -\frac{3}{2}x + 6$ . Graph.

4. The graph shows how the length (measured in cm) of a pendulum is related to the time (measured in sec) needed for the pendulum to make one complete back-and-forth movement (which is called the *period*). Find the length of a pendulum that swings twice as often as a 30-cm pendulum.

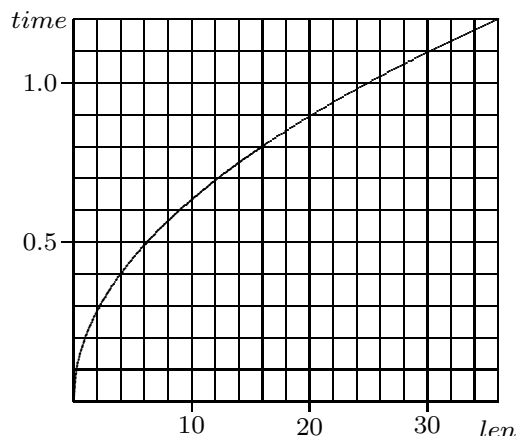

5. How far apart on a number line are
  - (a) 12 and 18?
  - (b) 12 and  $-7$ ?
  - (c)  $-11$  and  $-4$ ?
6. A toy manufacturer is going to produce a new toy car. Each one costs \$3 to make, and the company will also have to spend \$200 to set up the machinery to make them.
  - (a) What will it cost to produce the first hundred cars? the first  $n$  cars?
  - (b) The company sells the cars for \$4 each. Thus the company takes in \$400 by selling one hundred cars. How much money does the company take in by selling  $n$  cars?
  - (c) How many cars does the company need to make and sell in order to make a profit?
7. What is the distance between 6 and  $-6$ ? between 24 and 17? between 17 and 24? between  $t$  and 4? The distance between two points is always positive. If  $a$  and  $b$  are two points on a number line, the distance is therefore either  $a - b$  or  $b - a$ , whichever is nonnegative. This is an example of an *absolute-value* calculation, and the result is written  $|a - b|$ . What is the meaning of  $|b - a|$ ?
8. A cyclist rides 30 km at an average speed of 9 km/hr. At what rate must the cyclist cover the next 10 km in order to bring the overall average speed up to 10 km/hr.?
9. Let  $P = (x, y)$  and  $Q = (1, 5)$ . Write an equation that states that the slope of line  $PQ$  is 3. Show how this slope equation can be rewritten in the form  $y - 5 = 3(x - 1)$ . This linear equation is said to be in *point-slope form*. Explain the terminology. Find coordinates for three different points  $P$  that fit this equation.
10. (Continuation) What do the lines  $y = 3(x - 1) + 5$ ,  $y = 2(x - 1) + 5$ , and  $y = -\frac{1}{2}(x - 1) + 5$  all have in common? How do they differ from each other?
11. Another word chain: Turn *big* into *red* into *win*. Change one letter at a time, always spelling real words.

## Mathematics 1

1. Given that  $48 \leq n \leq 1296$  and  $24 \leq d \leq 36$ , what are the largest and smallest values that the expression  $\frac{n}{d}$  can possibly have? Write your answer  $\textit{smallest} \leq \frac{n}{d} \leq \textit{largest}$ .

2. Jess has 60 ounces of an alloy that is 40% gold. How many ounces of pure gold must be added to this alloy to create a new alloy that is 75% gold?

3. The table at right shows data that Morgan collected during a 10-mile bike ride that took 50 minutes. The cumulative distance (measured in miles) is tabled at ten-minute intervals.

<i>time</i>	<i>dist</i>
0.0	0.0
10.0	2.3
20.0	4.4
30.0	5.7
40.0	8.2
50.0	10.0

(a) Make a scatter plot of this data. Why might you expect the data points to line up? Why do they not line up?

(b) Morgan's next bike ride lasted for 90 minutes. Estimate its length (in miles), and explain your method. What if the bike ride had lasted  $t$  minutes; what would its length be, in miles?

4. Write an equation for the line that goes through the point (1,5) and that has slope  $\frac{2}{3}$ .

5. The equation  $5x - 8y = 20$  expresses a linear relationship between  $x$  and  $y$ . The point (15, 7) is either on the graph of this line, above it, or below it. Which? How do you know?

6. Write an equation for the line that contains the points in the table, and make up a context for it.

$x$	0	15	30	45	60
$y$	100	160	220	280	340

7. On a number line, how far is each of the following numbers from zero?

(a) 45                      (b)  $-7$                       (c)  $x$                       (d)  $x + 2$                       (e) 0

8. Solve (a)  $A = \frac{1}{2}bh$  for  $b$ ; (b)  $A = 2\pi rh + \pi r^2$  for  $h$ .

9. On a number line, how far is each of the following numbers from 5?

(a) 17                      (b)  $-4$                       (c)  $x$                       (d)  $x + 3$                       (e)  $x - 1$

10. Interpret each of the following as the distance between two numbers on a number line.

(a)  $|x - 7|$                       (b)  $|3 - x|$                       (c)  $|x + 5|$                       (d)  $|x|$

11. To graph linear equations such as  $3x + 5y = 30$ , one can put the equation into slope-intercept form, but (unless the slope is needed) it is easier to find the  $x$ - and  $y$ -intercepts and use them to sketch the graph. Find the axis intercepts of each of the following and use them to draw the given line. An equation  $ax + by = c$  is said to be in *standard form*.

(a)  $20x + 50y = 1000$                       (b)  $4x - 3y = 72$

12. Find an equation for the line containing the points  $(-3, 0)$  and  $(0, 4)$ .

13. Multiply  $x + 2y$  by  $3y$ . Draw an algebra-block diagram to illustrate this calculation.



## Mathematics 1

- Write an equation in point-slope form for
  - the line that goes through  $(2, 5)$  and  $(6, -3)$ ;
  - the line that goes through point  $(h, k)$  and that has slope  $m$ .
- Casey goes for a bike ride from Exeter to Durham, while an odometer keeps a cumulative record of the number of miles traveled. The equation  $m = 12t + 37$  describes the odometer reading  $m$  after  $t$  hours of riding. What is the meaning of 12 and 37 in the context of this trip?
- Find an equation for the line that passes through the points  $(4.1, 3.2)$  and  $(2.3, 1.6)$ .
- Find coordinates for all the points on a number line that are
  - six units from 0;
  - six units from four;
  - six units from  $-7$ ;
  - six units from  $x$ .
- Rearrange the eight words “between”, “4”, “the”, “17”, “is”, “and”, “ $x$ ”, and “distance” to form a sentence that is equivalent to the equation  $|x - 17| = 4$ . By working with a number line, find the values of  $x$  that fit the equation.
- As you know, temperatures can be measured by either Celsius or Fahrenheit units;  $30^\circ C$  is equivalent to  $86^\circ F$ ,  $5^\circ C$  is equivalent to  $41^\circ F$ , and  $-10^\circ C$  is equivalent to  $14^\circ F$ .
  - Plot this data with  $C$  on the horizontal axis and  $F$  on the vertical axis.
  - Verify that these three data points are *collinear*.
  - Find a linear equation that relates  $C$  and  $F$ .
  - Graph  $F$  versus  $C$ . In other words, graph the linear equation you just found.
  - Graph  $C$  versus  $F$ . You will need to re-plot the data, with  $C$  on the vertical axis.
  - On New Year’s Day, I heard a weather report that said the temperature was a balmy  $24^\circ C$ . Could this have happened? What is the corresponding Fahrenheit temperature?
  - Water boils at  $212^\circ F$  and freezes at  $32^\circ F$  at sea level. Find the corresponding Celsius temperatures.
  - Is it ever the case that the temperature in degrees Fahrenheit is the same as the temperature in degrees Celsius?
- A recent CNN poll about crime in schools reported that 67% of the persons polled were in favor of a crime bill currently being debated in Congress. CNN also reported that there was a 3% margin of error in the statistics. Explain why the range of possible percentage points can therefore be written as  $|x - 0.67| \leq 0.03$ .
- Translate the sentence “the distance between  $x$  and 12 is 20” into an equation using algebraic symbols. What are the values of  $x$  being described?
- In 1990 a company had a profit of \$420000. In 1995 it reported a profit of \$1400000. Find the average rate of change of its profit for that period, expressed in dollars per year.
- Translate “ $x$  is 12 units from 20” into an equation. What are the values of  $x$  being described?

## Mathematics 1

1. Twelve flags are evenly spaced around a running track. Ryan started running at the first flag and took 30 seconds to reach the sixth flag. How many seconds did it take Ryan, running at a constant rate, to reach (a) the 10<sup>th</sup> flag for the first time? (b) the 8<sup>th</sup> flag for the 2<sup>nd</sup> time? (c) the  $n^{\text{th}}$  flag for the  $m^{\text{th}}$  time?

2. Translate the sentence “ $x$  and  $y$  are twelve units apart” into algebraic code. Find a pair  $(x, y)$  that fits this description. How many pairs are there?

3. The equation  $|x - 7| = 2$  is a translation of “the distance from  $x$  to 7 is 2.”

(a) Translate  $|x - 7| \leq 2$  into English, and graph its solutions on a number line.

(b) Convert “the distance from  $-5$  to  $x$  is at most 3” into symbolic form, and solve it.

4. It is common practice to read  $-75 < 2$  as “ $-75$  is less than 2.” Yet, in a significant sense, it is really  $-75$  that is the larger of the two numbers! Discuss the two meanings of “less than.”

5. Verify that  $(0, 4)$  is on the line  $3x + 2y = 8$ . Find another point on this line. Use these points to calculate the slope of the line. Is there another way to find the slope of the line?

6. Graph a horizontal line through the point  $(3, 5)$ . Choose another point on this line. What is the slope of this line? What is the  $y$ -intercept of this line? What is an equation for this line? Describe a context that could be modeled by this line.

7. Graph a vertical line through the point  $(3, 5)$ . Does this line have a slope or  $y$ -intercept? What is an equation for this line? Describe a context that could be modeled by this line.

8. After successfully solving an absolute-value problem, Ariel spilled Heath Bar Crunch® all over the problem. All that can be read now is, “The distance between  $x$  and (mess of ice cream) is (another mess of ice cream).” Given that Ariel’s answers are  $x = -3$  and  $x = 7$ , reconstruct the missing parts of the problem.

9. The figure shows the graph of  $20x + 40y = 1200$ . Find the  $x$ - and  $y$ -intercepts, the slope of the line, and the distances between tick marks on the axes. Duplicate this figure on your calculator. What window settings did you use?

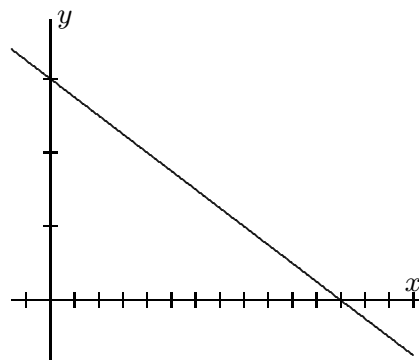

10. The *average* of three different positive integers is 8. What is the largest integer that could be one of them?

11. A handicapped-access ramp starts at ground level and rises 27 inches over a distance of 30 feet. What is the slope of this ramp?

12. Jay thinks that the inequality  $k < 3$  implies the inequality  $k^2 < 9$ , but Val thinks otherwise. Who is right, and why?

## Mathematics 1

1. The specifications for machining a piece of metal state that it must be 12 cm long, within a 0.01-cm tolerance. What is the longest the piece is allowed to be? What is the shortest? Using  $l$  to represent the length of the finished piece of metal, write an absolute-value inequality that states these conditions.

2. A movie theater charges \$6 for each adult and \$3 for each child. If the total amount in ticket revenue one evening was \$1428 and if there were 56 more children than adults, then how many children attended?

3. Pat and Kim are operating a handcar on the railroad tracks. It is hard work, and it takes an hour to cover each mile. Their big adventure starts at 8 am at Rockingham Junction, north of Exeter. They reach the Main St crossing in Exeter at noon, and finish their ride in Kingston at 3 pm. Let  $t$  be the number of hours since the trip began, and  $d$  be the corresponding distance (in miles) between the handcar and Main St. With  $t$  on the horizontal axis, draw a graph of  $d$  versus  $t$ , after first making a table of  $(t, d)$  pairs for  $0 \leq t \leq 7$ .

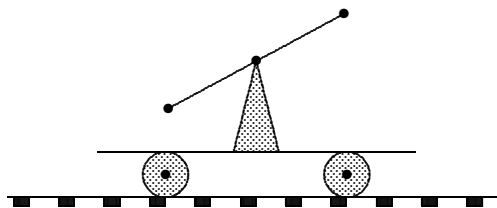

4. (Continuation) Graph the equation  $y = |x - 4|$  for  $0 \leq x \leq 7$ . Interpret this graph in the current context.

5. (Continuation) Let  $y$  be the distance between the handcar and the Newfields Road bridge, which Pat and Kim reach at 11 am. Draw a graph that plots  $y$  versus  $t$ , for the entire interval  $0 \leq t \leq 7$ . Write an equation that expresses  $y$  in terms of  $t$ . By the way, you have probably noticed that each of these absolute-value graphs has a corner point, which is called a *vertex*.

6. (Continuation) Solve the equation  $|t - 3| = 1$  and interpret the answers.

7. If  $|x + 1| = 5$ , then  $x + 1$  can have two possible values, 5 and  $-5$ . This leads to two equations,  $x + 1 = 5$  and  $x + 1 = -5$ . If  $|2x - 7| = 5$ , what possible values could the expression  $2x - 7$  have? Write two equations using the expression  $2x - 7$  and solve them.

8. Write two equations without absolute value symbols that, in combination, are equivalent to  $|3x + 5| = 12$ . Solve each of these two equations.

9. Given that  $0.0001 \leq n \leq 0.01$  and  $0.001 \leq d \leq 0.1$ , what are the largest and smallest values that  $\frac{n}{d}$  can possibly have? Write your answer  $\text{smallest} \leq \frac{n}{d} \leq \text{largest}$ .

10. A *lattice point* is defined as a point whose coordinates are integers. If  $(-3, 5)$  and  $(2, 1)$  are two points on a line, find three other lattice points on the same line.

11. The equation  $13x + 8y = 128$  expresses a linear relationship between  $x$  and  $y$ . The point  $(5, 8)$  is on, or above, or below the linear graph. Which is it? How do you know?

## Mathematics 1

1. Show that the equation  $y = \frac{7}{3}x - \frac{11}{8}$  can be rewritten in the standard form  $ax + by = c$ , in which  $a$ ,  $b$ , and  $c$  are all integers.

2. Fill in the blanks:

(a) The inequality  $|x - 1.96| < 1.04$  is equivalent to “ $x$  is between \_\_\_\_\_ and \_\_\_\_\_.”

(b) The inequality  $|x - 2.45| \geq 4.5$  is equivalent to “ $x$  is not between \_\_\_\_\_ and \_\_\_\_\_.”

3. Find the value for  $h$  for which the slope of the line through  $(-5, 6)$  and  $(h, 12)$  is  $3/4$ .

4. Solve the equation  $0.05x + 0.25(30 - x) = 4.90$ . Invent a context for the equation.

5. The data in each table fits a direct variation. Complete each table, write an equation to model its data, and sketch a graph.

(a) 

$x$	2	4	6	
$y$	3	6		18

(b) 

$x$	2	3		8
$y$	-8	-12	-20	

6. For each of the following equations, find the  $x$ -intercept and  $y$ -intercept. Then use them to calculate the slope of the line.

(a)  $3x + y = 6$

(b)  $x - 2y = 10$

(c)  $4x - 5y = 20$

(d)  $ax + by = c$

7. Blair’s average on the first five in-class tests is 67. If this is not pulled up to at least a 70, Blair will not be allowed to watch any more *Law and Order* reruns. To avoid losing those TV privileges, what is the lowest score Blair can afford to make on the last in-class test? Assume that all tests carry equal weight.

8. Sketch the graphs of  $y = 2x$ ,  $y = 2x + 1$ , and  $y = 2x - 2$  all on the same coordinate-axis system. Find the slope of each line. How are the lines related to one another?

9. I have 120 cm of framing material to make a picture frame, which will be most pleasing to the eye if its height is  $2/3$  of its width. What dimensions should I use?

10. Describe the relationship between the following pairs of numbers:

(a)  $24 - 11$  and  $11 - 24$

(b)  $x - 7$  and  $7 - x$

(c)  $|x - 7|$  and  $|7 - x|$

11. In each case, decide whether the three points given are collinear:

(a)  $(-4, 8)$ ,  $(0, 2)$ , and  $(2, -1)$

(b)  $(350, 125)$ ,  $(500, 300)$ , and  $(650, 550)$

12. Graph  $y = |x - 5|$  and  $y = |x + 3|$ , then describe in general terms how the graph of  $y = |x|$  is transformed to produce the graph of  $y = |x - h|$ .

13. Write an equation for each of the graphs shown at right. Each graph goes through several lattice points.

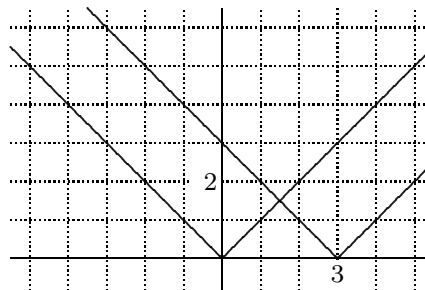

## Mathematics 1

1. A horse thief riding at 8 mph has a 32-mile head start. The posse in pursuit is riding at 10 mph. In how many hours will the thief be overtaken? [From *The New Arithmetic*, Seymour Eaton, 1885]

2. Write  $(x + 1)(x + 2)$  without parentheses. Explain how the diagram at right illustrates this product.

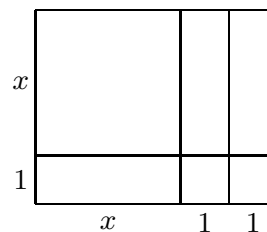

3. Solve the equation  $C = \frac{5}{9}(F - 32)$  for  $F$ .

4. Draw the line through the point  $(0, 6)$  whose slope is  $\frac{2}{3}$ . If you move 24 units to the right of  $(0, 6)$ , and then move up to the line, what is the  $y$ -coordinate of the point you reach?

5. (Continuation) Find an equation for the line. What is the  $x$ -intercept of the line?

6. Sketch on the same axes the graphs of  $y = |x|$  and  $y = |x| - 2$ . Label the  $x$ - and  $y$ -intercepts. In what respects are the two graphs similar? In what respects do they differ?

7. The manager at Jen and Berry's Ice Cream Company estimates that the cost  $C$  (in dollars) of producing  $n$  quarts of ice cream in a given week is given by the equation  $C = 560 + 1.20n$ .

(a) During one week, the total cost of making ice cream was \$1070. How many quarts were made that week?

(b) Explain the meanings of the "560" and the "1.20" in the cost equation.

8. As anyone knows who has hiked up a mountain, the higher you go, the cooler the temperature gets. At noon on July 4th last summer, the temperature at the top of Mt. Washington — elevation 6288 feet — was  $56^\circ F$ . The temperature at base camp in Pinkham Notch — elevation 2041 feet — was  $87^\circ F$ . It was a clear, still day. At that moment, a group of hikers reached Tuckerman Junction — elevation 5376 feet. To the nearest degree, calculate the temperature the hikers were experiencing at that time and place. When you decided how to model this situation, what assumptions did you make?

9. Draw a line through the origin with a slope of 0.4. Draw a line through the point  $(1, 2)$  with a slope of 0.4. How are these two lines related? What is the vertical distance between the two lines? Find an equation for each line.

10. Graph  $y = |x| + 3$  and  $y = |x| - 5$ , then describe in general terms how the graph of  $y = |x|$  is transformed to produce the graph of  $y = |x| + k$ . How can you tell from the graph whether  $k$  is positive or negative?

11. Randy phones Sandy about a homework question, and asks, "The vertex of the graph of  $y$  equals the absolute value of  $x$  plus four is  $(-4, 0)$ , isn't it?" Sandy answers, "No, the vertex is  $(0, 4)$ ." Who is right? Explain.

## Mathematics 1

1. Solve  $\frac{3m}{4} + \frac{3}{8} = \frac{m}{3} - \frac{5}{6}$  for  $m$ , expressing your answer as a fraction in lowest terms.
2. Find two different ways of determining the slope of the line  $11x + 8y = 176$ .
3. Find the  $x$ - and  $y$ -intercepts of  $y = |x - 3| - 5$ , find the coordinates of its vertex, and then sketch the graph of this equation.
4. When weights are placed on the end of a spring, the spring stretches. If a three-pound weight stretches the spring to a length of 4.25 inches, a five-pound weight stretches the spring to a length of 5.75 inches, and a nine-pound weight stretches the spring to a length of 8.75 inches, what was the initial length of the spring?
5. Given that  $y$  varies directly with  $x$  and that  $y = 60$  when  $x = 20$ , find  $y$  when  $x = 12$ .
6. Draw rectangles that are composed of  $x^2$ -blocks,  $x$ -blocks, and 1-blocks to illustrate the results when the following *binomial* products are expanded:  
(a)  $(x + 2)(x + 3)$                       (b)  $(2x + 1)(x + 1)$                       (c)  $(x + 2)(x + 2)$
7. Solve for  $x$ :  $\frac{1}{2}(x - 2) + \frac{1}{3}(x - 3) + \frac{1}{4}(x - 4) = 10$
8. Sketch on the same axes the graphs of  
(a)  $y = |x|$                       (b)  $y = 2|x|$                       (c)  $y = 0.5|x|$                       (d)  $y = -3|x|$
9. What effect does the coefficient  $a$  have on the graph of the equation  $y = a|x|$ ? How can you tell whether  $a$  is positive or negative by looking at the graph?
10. Find the  $x$ - and  $y$ -intercepts of  $y = 5 - |x - 3|$ , find the coordinates of its vertex, and then sketch the graph of this equation.
11. A chemist would like to dilute a 20-cc solution that is 5% acid to one that is 3% acid. How much water must be added to accomplish this task?
12. A cube measures  $x$  cm on each edge.  
(a) Find a formula in terms of  $x$  for the volume of this cube in cubic centimeters (cc).  
(b) Evaluate this formula when  $x = 1.5$  cm; when  $x = 10$  cm.  
(c) Write an expression for the area of one of the faces of the cube. Write a formula for the total surface area of all six faces.  
(d) Evaluate this formula when  $x = 1.5$  cm; when  $x = 10$  cm.  
(e) Although area is measured in square units and volume in cubic units, is there any cube for which the number of square units in the area of its faces would equal the number of cubic units in the volume?
13. Apply the distributive property to write without parentheses and collect like terms:  
(a)  $x(x - 3) + 2(x - 3)$                       (b)  $2x(x - 4) - 3(x - 4)$                       (c)  $x(x - 2) + 2(x - 2)$

## Mathematics 1

1. The fuel efficiency of a car depends on the speed at which it is driven. For example, consider Kit's Volvo. When it is driven at  $r$  miles per hour, it gets  $m = 32 - 0.2|r - 55|$  miles per gallon. Graph  $m$  versus  $r$ , for  $0 < r \leq 80$ . Notice that this graph has a vertex. What are its coordinates?

2. (Continuation) Solve the inequality  $30 \leq 32 - 0.2|r - 55|$ , and express the solution interval graphically. What is the meaning of these  $r$ -values to Kit?

3. Asked to solve the inequality  $3 < |x - 5|$  at the board, Corey wrote " $8 < x < 2$ ," Sasha wrote " $x < 2$  or  $8 < x$ ," and Pat wrote " $x < 2$  and  $8 < x$ ." What do you think of these answers? Do any of them agree with your answer?

4. Apply the distributive property to write without parentheses and collect like terms:

(a)  $(x + 2)(x - 3)$

(b)  $(2x - 3)(x - 4)$

(c)  $(x + 2)(x - 2)$

5. If the width and length of a rectangle are both increased by 10%, by what percent does the area of the rectangle increase? By what percent does the perimeter of the rectangle increase?

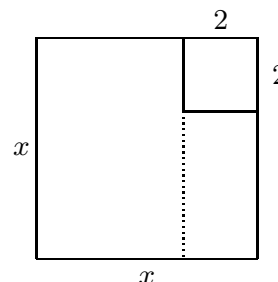

6. By rearranging the pieces of the puzzle shown at right, you can demonstrate that  $x^2 - 4$  is equivalent to  $(x + 2)(x - 2)$  *without* using the distributive property. Show how to do it.

7. Compare the graphs of  $y = x - 3$  and  $y = |x - 3|$ . How are they related?

8. Morgan's way to solve the equation  $|2x - 7| = 5$  is to first write  $|x - 3.5| = 2.5$ . Explain this approach, then finish the job.

9. A 20-mile road runs between Buzzardtown and Dry Gulch. Each town has a gas station, but there are no gas stations between the towns. Let  $x$  be the distance along the road from Buzzardtown, and  $y$  be the distance to the nearest gas station. Make a table of values that includes entries for  $x = 7$ ,  $x = 9$ , and  $x = 16$ , and then draw a graph of  $y$  versus  $x$ . The vertex of the graph should be at  $(10, 10)$ .

10. (Continuation) Graph the equation  $y = 10 - |x - 10|$ . Explain its significance to the story.

11. (Continuation) Suppose that you are in a car that has been traveling along the Buzzardtown-Dry Gulch road for  $t$  minutes at 30 miles per hour. How far is it to the nearest gas station, in terms of  $t$ ? Graph this distance versus  $t$ . What are the coordinates of the vertex of your graph?

12. A train is leaving in 11 minutes and you are one mile from the station. Assuming you can walk at 4 mph and run at 8 mph, how much time can you afford to walk before you must begin to run in order to catch the train?

## Mathematics 1

1. Sandy was told by a friend that “absolute value makes everything positive.” So Sandy rewrote the equation  $|x - 6| = 5$  as  $x + 6 = 5$ . Do you agree with the statement, or with what Sandy did to the equation? Explain your answer.

2. For each of the following points, find the distance to the  $y$ -axis:

- (a)  $(11, 7)$                       (b)  $(-5, 9)$                       (c)  $(4, y)$                       (d)  $(x, -8)$

3. To mail a first-class letter in 2006, the rate was 39 cents for the first ounce or fraction thereof, and 24 cents for each additional ounce or fraction thereof. Let  $p$  be the number of cents needed to mail a first-class letter that weighed  $w$  ounces. Graph  $p$  versus  $w$ , after first making a table that includes some non-integer values for  $w$ .

4. Given the line  $y = \frac{1}{2}x + 6$ , write an equation for the line through the origin that has the same slope. Write an equation for the line through  $(2, -4)$  that has the same slope.

5. The table shows the population of New Hampshire at the start of each of the last six decades.

<i>year</i>	<i>pop</i>
1950	533242
1960	606921
1970	746284
1980	920610
1990	1113915
2000	1238415

(a) Write an equation for the line that contains the data points for 1950 and 2000.

(b) Write an equation for the line that contains the data points for 1990 and 2000.

(c) Make a scatter plot of the data. Graph both lines on it.

(d) Use each of these equations to predict the population of New Hampshire at the beginning of 2010. For each prediction, explain why you could expect it to provide an accurate forecast.

6. Which of the following calculator screens could represent the graph of  $9x + 5y = 40$ ?

(a)

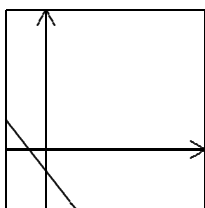

(b)

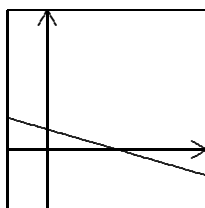

(c)

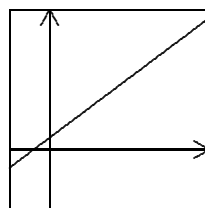

(d)

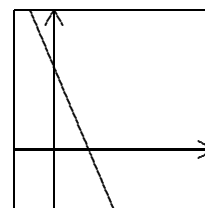

7. For each of these absolute-value equations, write two equations without absolute-value symbols that are equivalent to the original. Solve each of the equations.

- (a)  $2|x + 7| = 12$                       (b)  $3 + |2x + 5| = 17$                       (c)  $6 - |x + 2| = 3$                       (d)  $-2|4 - 3x| = -14$

8. Hearing Yuri say “This line has no slope,” Tyler responds “Well, ‘no slope’ actually means slope 0.” What are they talking about? Do you agree with either of them?

9. A flat, rectangular board is built by gluing together a number of square pieces of the same size. The board is  $m$  squares wide and  $n$  squares long. In terms of  $m$  and  $n$ , write two different expressions for the number of completely surrounded squares.



## Mathematics 1

1. The edges of a solid cube are  $3p$  cm long. At one corner of the cube, a small cube is cut away. All its edges are  $p$  cm long. In terms of  $p$ , what is the total surface area of the remaining solid? What is the volume of the remaining solid? Make a sketch.
2. Lee's pocket change consists of  $x$  quarters and  $y$  dimes. Put a dot on every lattice point  $(x, y)$  that signifies that Lee has exactly one dollar of pocket change. What equation describes the line that passes through these points? Notice that it does not make sense to connect the dots in this context, because  $x$  and  $y$  are *discrete* variables, whose values are limited to integers.
3. (Continuation) Put a dot on every lattice point  $(x, y)$  that signifies that Lee has at most one dollar in pocket change. How many such dots are there? What is the relationship between Lee's change situation and the inequality  $0.25x + 0.10y \leq 1.00$ ?
4. (Continuation) Write two inequalities that stipulate that Lee cannot have fewer than zero quarters or fewer than zero dimes.

5. The figure shows the graphs of two lines. Use the graphs (the axis markings are one unit apart) to estimate the coordinates of the point that belongs to both lines.

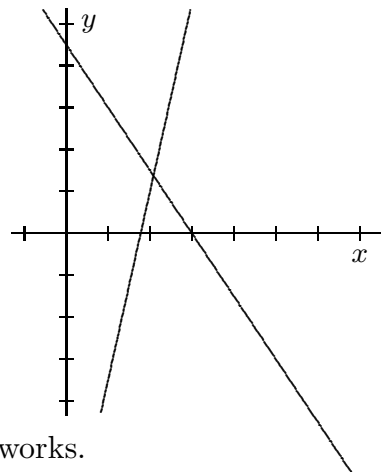

6. (Continuation) The *system of equations* that has been graphed is

$$\begin{cases} 9x - 2y = 16 \\ 3x + 2y = 9 \end{cases}$$

Jess took one look at these equations and knew right away what to do. "Just add the equations and you will find out quickly what  $x$  is." Follow this advice, and explain why it works.

7. (Continuation) Find the missing  $y$ -value by inserting the  $x$ -value you found into either of the two original equations. Do the coordinates of the intersection point agree with your estimate? These coordinates are called a *simultaneous solution* of the original system of equations. Explain the terminology.
8. Using four  $x$ -blocks:
  - (a) Draw a rectangle. Write the dimensions of your rectangle. What is its area?
  - (b) Draw a rectangle with dimensions different from those you used in part (a).
9. The solution of  $|x| = 6$  consists of the points 6 and  $-6$ . Show how to use a test point on the number line to solve and graph the inequality  $|x| \leq 6$ . Do the same for  $|x| \geq 6$ .
10. Most linear equations can be rewritten in slope-intercept form  $y = mx + b$ . Give an example that shows that not all linear equations can be so rewritten.

## Mathematics 1

1. Which of the following could be the equation that is graphed on the calculator screen shown at right?

- (a)  $3y - 7x = 28$                       (b)  $x + 2y = 5$   
 (c)  $12x = y + 13$                       (d)  $y - 0.01x = 2000$

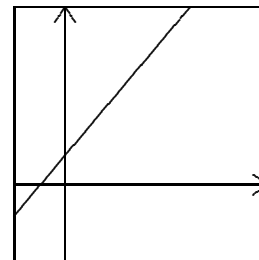

2. Draw a rectangle using two  $x^2$ -blocks and two  $x$ -blocks. Write the dimensions of your rectangle. What is the area of the rectangle?

3. (Continuation) Using the same two  $x^2$ -blocks and same two  $x$ -blocks, draw a different rectangle. What is the area of the rectangle?

4. (Continuation) One of your diagrams illustrates the equation  $x(2x + 2) = 2x^2 + 2x$ . Explain. Write an equation that is illustrated by the other diagram.

5. Find values for  $x$  and  $y$  that fit both of the equations  $2x - 3y = 8$  and  $4x + 3y = -2$ .

6. The figure at right shows the graphs of two lines. Use the figure to estimate the coordinates of the point that belongs to both lines. The system of equations is

$$\begin{cases} 3x + 2y = 6 \\ 3x - 4y = 17 \end{cases}$$

Randy took one look at these equations and knew right away what to do. "Just subtract the equations and you will find out quickly what  $y$  is." Follow this advice.

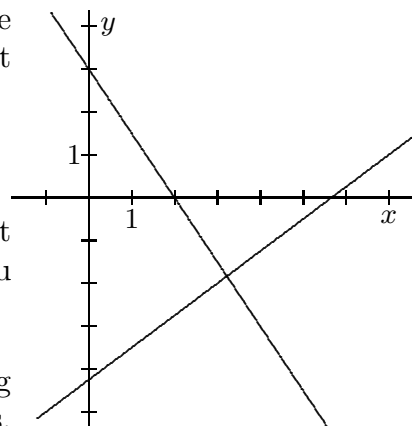

7. (Continuation) Find the missing  $x$ -value by inserting the  $y$ -value you found into one of the two original equations. Does it matter which one? Compare the intersection coordinates with your estimate.

8. (Continuation) If you *add* the two given equations, you obtain the equation of yet another line. Add its graph to the figure. You should notice something. Was it expected?

9. Brett is holding three quarters and five dimes. Does Brett have more than one dollar or less than one dollar? Does the point  $(3, 5)$  lie above or below the line  $0.25x + 0.10y = 1.00$ ?

10. Find the value of  $x$  that fits the equation  $\frac{1}{2}x + \frac{1}{3}x + \frac{1}{4}x = 26$ .

11. A hot-air balloon ride has been set up so that a paying customer is carried straight up at 50 feet per minute for ten minutes and then immediately brought back to the ground at the same rate. The whole ride lasts twenty minutes. Let  $h$  be the height of the balloon (in feet) and  $t$  be the number of minutes since the ride began. Draw a graph of  $h$  versus  $t$ . What are the coordinates of the vertex? Find an equation that expresses  $h$  in terms of  $t$ .

## Mathematics 1

1. A movie club has a membership fee of \$50, after which individual movies can be bought for \$5.50. Non-members pay \$8.00 per movie. If you are going to buy a lot of movies, it is better to pay the membership fee. How many movies is “a lot”?

2. What is the slope of the line graphed at the right, if  
(a) the distance between the  $x$ -tick marks is 2 units and the distance between the  $y$ -tick marks is 1 unit?

(b) the distance between the  $x$ -tick marks is 100 units and the distance between the  $y$ -tick marks is 5 units?

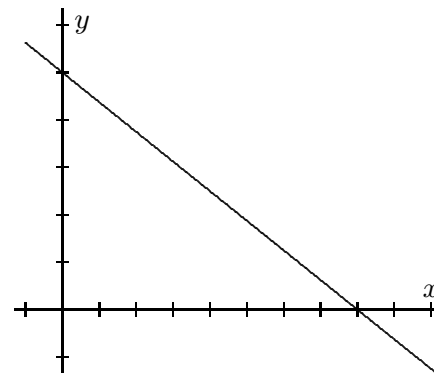

3. My sleeping bag is advertised to be suitable for temperatures  $T$  between 20 degrees below zero and 20 degrees above zero (Celsius). Write an absolute-value inequality that describes these temperatures  $T$ .

4. Draw a rectangle using one  $x^2$ -block, three  $x$ -blocks and two 1-blocks to illustrate the equation  $x^2 + 3x + 2 = (x + 1)(x + 2)$ . What are the dimensions of the rectangle? This equation is called an *identity* because it is true no matter what value is assigned to  $x$ .

5. Graph the equation  $2x + 3y = 6$ . Now graph the inequality  $2x + 3y \leq 6$  by shading all points  $(x, y)$  that fit it. Notice that this means shading all the points on one side of the line you drew. Which side? Use a test point like  $(0, 0)$  to decide.

6. Some questions about the line that passes through the points  $(-3, -2)$  and  $(5, 6)$ :

(a) Find the slope of the line.

(b) Is the point  $(10, 12)$  on the line? Justify your answer.

(c) Find  $y$  so that the point  $(7, y)$  is on the line.

7. Find values for  $x$  and  $y$  that fit both of the equations  $5x + 3y = 8$  and  $4x + 3y = -2$ .

8. A 100-liter barrel of vinegar is 8% acetic acid. Before it can be bottled and used in cooking, the acidity must be reduced to 5% by diluting it with pure water. In order to produce 64 liters of usable vinegar, how many liters of vinegar from the barrel and how many liters of pure water should be combined?

9. Casey can peel  $k$  apples in 10 minutes.

(a) In terms of  $k$ , how many apples can Casey peel in one minute?

(b) How many apples can Casey peel in  $m$  minutes?

(c) In terms of  $k$ , how many minutes does it take Casey to peel one apple?

(d) How many minutes does it take Casey to peel  $p$  apples?

10. Express each as a single fraction: (a)  $\frac{1}{a} + \frac{2}{b} + \frac{3}{c}$  (b)  $\frac{1}{a} + \frac{1}{b+c}$  (c)  $1 + \frac{2}{a+b}$

11. Graph  $y = 3|x - 2| - 6$ , and find coordinates for the vertex and the  $x$ - and  $y$ -intercepts.

## Mathematics 1

1. The figure at right shows the graphs of two lines. Use the figure to estimate the coordinates of the point that belongs to both lines. The system of equations is

$$\begin{cases} 4x + 3y = 20 \\ 3x - 2y = -5 \end{cases}$$

Lee took one look at these equations and announced a plan: “Just multiply the first equation by 2 and the second equation by 3.” What does changing the equations in this way do to their graphs?

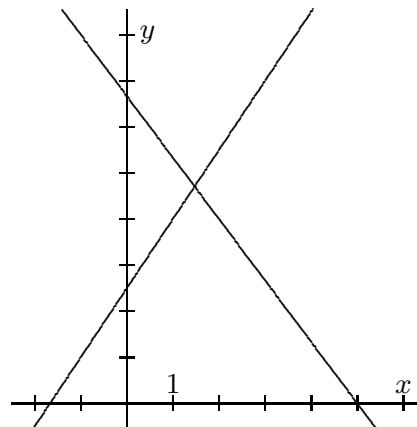

2. (Continuation) Lee’s plan has now created a familiar situation. Do you recognize it? Complete the solution to the system of equations. Do the coordinates of the point of intersection agree with your initial estimate?

3. The diagram consists of two  $x^2$ -blocks, five  $x$ -blocks and three 1-blocks. Use this diagram to write a statement that says that the product of the length and width of this particular rectangle is the same as its area. Can you draw another rectangle with the same area but different dimensions?

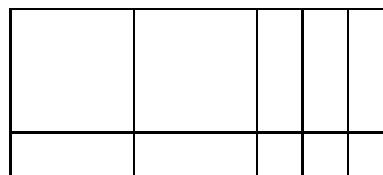

4. Sandy’s first four test scores this term are 73, 87, 81 and 76. To have at least a B test grade, Sandy needs to average at least 80 on the five term tests (which count equally). Let  $t$  represents Sandy’s score on the fifth test, and write an inequality that describes the range of  $t$ -values that will meet Sandy’s goal.

5. Graph solutions on a number line: (a)  $|x+8| < 20$  (b)  $|2x-5| \leq 7$  (c)  $3|4-x| \geq 12$

6. Shade the points in the plane whose  $x$ -coordinates are greater than their  $y$ -coordinates. Write an inequality that describes these points.

7. The diagram at right shows a rectangle that has been cut into nine square pieces, no two being the same size. Given that the smallest piece is 2 cm by 2 cm, figure out the sizes of the other eight pieces. A good strategy is to start by guessing the size of one of the pieces adjacent to the smallest piece. By checking your guess, you will discover the hidden equation.

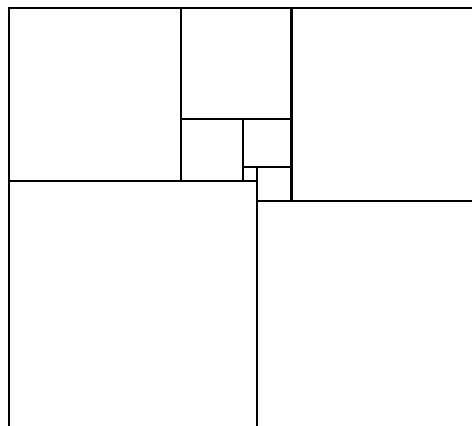

8. Solve the system of equations  $2x + y = 5$  and  $5x - 2y = 8$  algebraically. Check your answer graphically.

## Mathematics 1

- Raisins make up two thirds of a well-mixed bowl of peanuts and raisins. If half the mixture is removed and replaced with peanuts, what fraction of the bowl will be raisins?
- A large telephone company sent out an offer for pre-paid phone cards. The table below accompanied the ad and summarized their offer. Does this data form a linear relationship? Explain your answer. Which offer has the best rate per minute?

75-minute card	150-minute card	300-minute card	500-minute card	1000-minute card	1500-minute card
\$4.95	\$9.90	\$19.80	\$30.00	\$56.00	\$75.00

- Find an equation for each of the following lines. When possible, express your answer in both point-slope form and slope-intercept form.
  - The line passes through  $(3, 5)$ , and has  $-1.5$  as its slope.
  - The line is parallel to the line through  $(-8, 7)$  and  $(-3, 1)$ , and has 6 as its  $x$ -intercept.
  - The line is parallel to the line  $x = -4$ , and it passes through  $(4, 7)$ .
- Jess and Wes used to race each other when they were younger. Jess could cover 8 meters per second, but Wes could cover only 5 meters per second, so Jess would sportingly let Wes start 60 meters ahead. They would both start at the same time and continue running until Jess caught up with Wes. How far did Jess run in those races?
- Use a different color for the regions described in parts (a) and (b):
  - Shade all points whose  $x$ - and  $y$ -coordinates sum to less than 10.
  - Shade all points whose  $x$ - and  $y$ -coordinates are both greater than zero.
  - Write a system of three inequalities that describe where the two regions overlap.

- The figure at right shows the graphs of two lines. Use the figure to estimate the coordinates of the point that belongs to both lines. The system of equations is

$$\begin{cases} 4x + 3y = 20 \\ y = 2x - 2 \end{cases}$$

Dale took one look at these equations and offered a plan: "The second equation says you can *substitute*  $2x - 2$  for  $y$  in the first equation. Then you have only one equation to solve." Explain the logic behind Dale's substitution strategy. Carry out the plan, and compare the exact coordinates of the intersection point with your estimates.

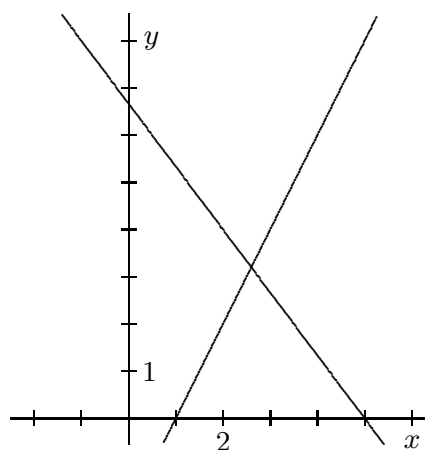

- Farmer MacGregor wants to know how many cows and ducks are in the meadow. After counting 56 legs and 17 heads, the farmer knows. How many cows and ducks are there?
- What are the  $x$ - and  $y$ -intercepts of  $y = |x - h| + k$ , and what are the coordinates of its vertex?

## Mathematics 1

1. Create a rectangle by combining two  $x^2$ -blocks, three  $x$ -blocks and a single 1-block. Write expressions for the length and width of your rectangle. Using these expressions, write a statement that says that the product of the length and width equals the area.
2. (Continuation) Instead of saying, “Find the dimensions of a rectangle made with two  $x^2$ -blocks, three  $x$ -blocks and one 1-block”, mathematicians say “*Factor*  $2x^2 + 3x + 1$ .” It is also customary to write the answer  $2x^2 + 3x + 1 = (2x + 1)(x + 1)$ . Explain why the statement about the blocks is the same as the algebraic equation.
3. Three gears are connected so that two turns of the first wheel turn the second wheel nine times and three turns of the second wheel turn the third wheel five times.
  - (a) If you turn the first wheel once, how many times does the third wheel turn?
  - (b) How many times must you turn the first wheel so that the third wheel turns 30 times?
4. How much money do you have, if you have  $d$  dimes and  $n$  nickels? Express your answer in (a) cents; (b) dollars.
5. How many nickels have the same combined value as  $q$  quarters and  $d$  dimes?
6. Find the point  $(x, y)$  that fits both of the equations  $y = 1.5x + 2$  and  $9x + 4y = 41$ .
7. Sam boards a ski lift, and rides up the mountain at 6 miles per hour. Once at the top, Sam immediately begins skiing down the same slope, averaging 54 miles per hour, and does not stop until reaching the entrance to the lift. The whole trip, up and down, takes 40 minutes. How many miles long is the trip down the mountain?
8. If the price of a stock goes from \$4.25 per share to \$6.50 per share, by what percent has the value of the stock increased?
9. Your company makes spindles for the space shuttle. NASA specifies that the length of a spindle must be  $12.45 \pm 0.01$  cm. What does this mean? What are the smallest and largest acceptable lengths for these spindles? Write this range of values as an inequality, letting  $L$  stand for the length of the spindle. Write another inequality using absolute values that models these constraints.
10. Factor each expression and draw an algebra-block diagram:
  - (a)  $3x^2 + 12x$
  - (b)  $x^2 + 5x + 6$
  - (c)  $4xy + 2y^2$
11. Pat and Kim are walking in the same direction along Front Street at a rate of 4 mph. Pat started walking from the Library at 8 am, and Kim left from the same spot 15 minutes later. On the same coordinate-axis system, draw two graphs — one for Pat and one for Kim — that plot the distance from walker to Library versus time.

## Mathematics 1

1. What is unusual about the graphs of the equations  $9x - 12y = 27$  and  $-3x + 4y = -9$ ?

2. The fuel efficiency  $m$  (in miles per gallon) of a truck depends on the speed  $r$  (in miles per hour) at which it is driven. The relationship between  $m$  and  $r$  usually takes the form  $m = a|r - h| + k$ . For Sasha's truck, the optimal fuel efficiency is 24 miles per gallon, attained when the truck is driven at 50 miles per hour. When Sasha drives at 60 miles per hour, however, the fuel efficiency drops to only 20 miles per gallon.

(a) Find another driving speed  $r$  for which the fuel efficiency of Sasha's truck is exactly 20 mpg.

(b) Fill in the rest of the missing entries in the table.

(c) Draw graph of  $m$  versus  $r$ , for  $0 < r \leq 80$ .

(d) Find the values of  $k$ ,  $a$ , and  $h$ .

$r$	$m$
60	20
50	24
40	
30	
20	
10	

3. With parental assistance, Corey buys some snowboarding equipment for \$500, promising to pay \$12 a week from part-time earnings until the 500-dollar debt is retired. How many weeks will it take until the outstanding debt is under \$100? Write an inequality that models this situation and then solve it algebraically.

4. The rails on a railroad are built from thirty-foot sections. When a train wheel passes over the junction between two sections, there is an audible *click*. Inside a train that is traveling at 70 mph, how many clicks will a passenger hear each twenty seconds?

5. In attempting to calculate the carrying capacity of a cylindrical pipe, Avery measured the outer diameter to be 2 inches, neglecting to notice that the pipe was one eighth of an inch thick. By what percent did Avery overestimate the carrying capacity of the pipe?

6. On 3 January 2004, after a journey of 300 million miles, the rover Spirit landed on Mars and began sending back information to Earth. It landed only six miles from its target. This accuracy is comparable to shooting an arrow at a target fifty feet away and missing the exact center by what distance?

7. Graph  $y = 2|x + 1| - 3$ , then describe in general terms how the graph of  $y = |x|$  is transformed to produce the graph of  $y = a|x - h| + k$ .

## Mathematics 1

1. Find an equation for the line that passes through the point  $(-3, 6)$ , parallel to the line through the points  $(0, -7)$  and  $(4, -15)$ . Write your answer in point-slope form.

2. Sid has a job at Morgan Motors. The salary is \$1200 a month, plus 3% of the sales price of every car or truck Sid sells (this is called a *commission*).

(a) The total of the sales prices of all the vehicles Sid sold during the first month on the job was \$72000. What was Sid's income (salary plus commission)?

(b) In order to make \$6000 in a single month, how much selling must Sid do?

(c) Write a linear equation that expresses Sid's monthly income  $y$  in terms of the value  $x$  of the vehicles Sid sold.

(d) Graph this equation. What is the meaning of its  $y$ -intercept, and the meaning of its slope?

3. Five gerbils cost  $p$  dollars. How many dollars will it cost to buy  $g$  gerbils? How many gerbils can you purchase for  $d$  dollars?

4. Find the value of  $x$  that fits the equation  $1.24x - (3 - 0.06x) = 4(0.7 + 6)$ .

5. At the Exeter Candy Shop, Jess bought 5.5 pounds of candy — a mixture of candy priced at \$4 per pound and candy priced at \$3.50 per pound. Given that the bill came to \$20.75, figure out how many pounds of each type of candy Jess bought.

6. Explain how to evaluate  $4^3$  without a calculator. The small raised number is called an *exponent*, and  $4^3$  is a *power of 4*. Write  $4 \cdot 4 \cdot 4 \cdot 4 \cdot 4$  as a power of 4. Write the product  $4^3 \cdot 4^5$  as a power of 4.

7. Write an equation for each of the graphs at right.

8. Sketch the region that is common to the graphs of  $x \geq 2$ ,  $y \geq 0$ , and  $x + y \leq 6$ . Find the area of this region.

9. Does every system of equations  $px + qy = r$  and  $mx + ny = k$  have a simultaneous solution  $(x, y)$ ? Explain.

10. You have one  $x^2$ -block, six  $x$ -blocks (all of which you must use), and a supply of 1-blocks. How many different rectangles can you make? Draw an algebra-block diagram for each.

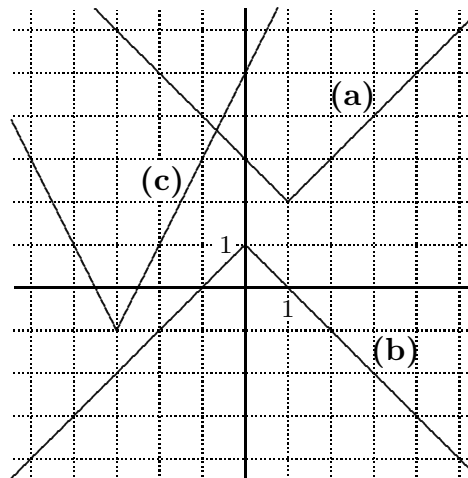



## Mathematics 1

1. Wes walks from home to a friend's house to borrow a bicycle, and then rides the bicycle home along the same route. By walking at 4 mph and riding at 8 mph, Wes takes 45 minutes for the whole trip. Find the distance that Wes walked.
2. Given that  $s$  varies directly with  $t$ , and that  $s = 4.56$  meters when  $t = 3$  seconds, find  $s$  when  $t$  is 4.2 seconds.
3. I recently paid \$85.28 for 12.2 pounds of coffee beans. What was the price per pound of the coffee? How many pounds did I buy per dollar?
4. What values of  $x$  satisfy the inequality  $|x| > 12$ ? Graph this set on a number line, and describe it in words. Answer the same question for  $|x - 2| > 12$ .

5. The figure at the right shows a rectangular box whose dimensions are 8 cm by 10 cm by 12 cm.

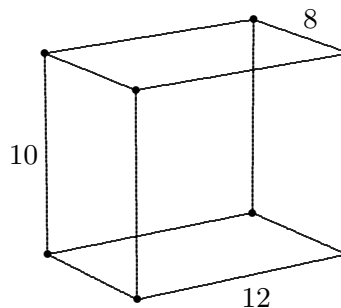

- (a) Find the volume of the solid.
- (b) What is the combined area of the six faces?
- (c) If you were to outline the twelve edges of this box with decorative cord, how much would you need?

6. The population of Exeter is about 15 thousand persons. The population of the United States is about 300 million persons. What percent of the US population lives in Exeter?
7. A rectangle is four times as long as it is wide. If its length were diminished by 6 meters and its width were increased by 6 meters, it would be a square. What are its dimensions?
8. What percent decrease occurs when a stock goes from \$6.50 per share to \$4.25 per share?
9. Sketch the region common to the graphs of  $y \geq -1$ ,  $y - 2x \leq 3$ , and  $x + y \leq 6$ . Find the area of this region.

10. Using the coordinate-axis system shown in the top view at right, the viewing area of a camera aimed at a mural placed on the  $x$ -axis is bordered by  $y = \frac{7}{8}|x| - 42$ . The dimensions are in feet. How far is the camera from the  $x$ -axis, and how wide a mural can be photographed?

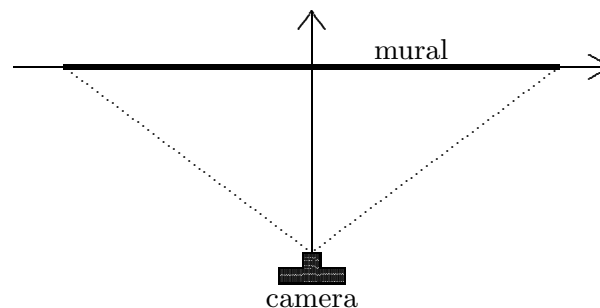

11. You have one  $x^2$ -block, twelve 1-blocks (all of which you must use), and an ample supply of  $x$ -blocks. How many rectangles with different dimensions can you make? Draw an algebra-block diagram for each.

## Mathematics 1

1. After a weekend of rock-climbing in the White Mountains, Dylan is climbing down a 400-foot cliff. It takes 20 minutes to descend the first 60 feet. Assuming that Dylan makes progress at a steady rate, write an equation that expresses Dylan's height  $h$  above level ground in terms of  $t$ , the number of minutes of descending. Use your equation to find how much time it will take Dylan to reach level ground.

2. Start with the equations  $2x - y = 3$  and  $3x + 4y = 1$ . Create a third equation by adding *any* multiple of the first equation to *any* multiple of the second equation. When you compare equations with your classmates, you will probably not agree. What is certain to be true about the graphs of *all* these third equations, however?

3. The Appalachian Trail is a hiking trail that stretches 2158 miles from Georgia to Maine. The record for completing this hike in the shortest time is 52 days. The record-setting hikers averaged 3 miles per hour. How many hours a day did they average?

4. The diagram at the right shows the wire framework for a rectangular box. The length of this box is 8 cm. greater than the width and the height is half the length. A total of 108 cm of wire was used to make this framework.

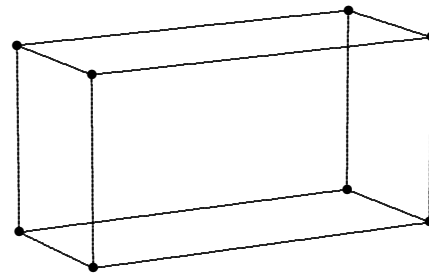

(a) What are the dimensions of the box?

(b) The faces of the box will be panes of glass. What is the total area of the glass needed for the six panes?

(c) What is the volume of the box?

5. A slow clock loses 25 minutes a day. At noon on the first of October, it is set to show the correct time. When will this clock next show the correct time?

6. Write a formula that expresses the distance between  $p$  and 17. Describe all the possible values for  $p$  if this distance is to be greater than 29.

7. You might not have seen an algebra-block diagram yet for a factorization that contains a minus sign. Try drawing a diagram to illustrate the identity  $2x^2 - x - 1 = (2x + 1)(x - 1)$ .

8. Cameron bought twelve pounds of candy corn for 79 cents a pound, and eighteen pounds of M&Ms for \$1.09 a pound, planning to make packages of candy for the Exeter-Andover game. The two types of candy will be mixed and sold in one-pound bags. At what price must Cameron sell these thirty bags in order to make at least a 25% profit?

9. A farmer has 90 meters of fencing material with which to construct three rectangular pens side-by-side as shown at right. If  $w$  were 10 meters, what would the length  $x$  be? Find a general formula that expresses  $x$  in terms of  $w$ .

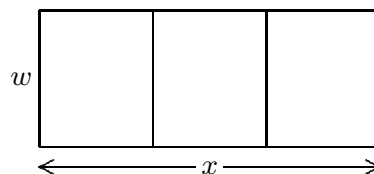

## Mathematics 1

1. Find how many pairs  $(x, y)$  satisfy the equation  $x + y = 25$ , assuming that
  - (a) there is no restriction on the values of  $x$  and  $y$ ;
  - (b) both  $x$  and  $y$  must be positive integers;
  - (c) the values of  $x$  and  $y$  must be equal.
  
2. Working alone, Jess can rake the leaves off a lawn in 50 minutes. Working alone, cousin Tate can do the same job in 30 minutes. Today they are going to work together, Jess starting at one end of the lawn and Tate starting simultaneously at the other end. In how many minutes will they meet and thus have the lawn completely raked?
  
3. (Continuation) Suppose that Tate takes a ten-minute break after just five minutes of raking. Revise your prediction of how many minutes it will take to complete the job.

4. The table at the right shows the value of a car as it depreciates over time. Does this data satisfy a linear relationship? Explain.

year	value
1992	24000
1993	20400
1994	16800
1995	13200

5. Write an inequality that describes all the points that are more than 3 units from 5.

6. If  $x$  varies directly with  $y$ , and if  $x = 5$  when  $y = 27$ , find  $x$  when  $y = 30$ .

7. Write and graph an equation that states
  - (a) that the perimeter of an  $l \times w$  rectangle is 768 cm;
  - (b) that the width of an  $l \times w$  rectangle is half its length.

8. (Continuation) Explain how the two graphs show that there is a unique rectangle whose perimeter is 768 cm, and whose length is twice its width. Find the dimensions of this rectangle.

9. When asked to solve the system of equations

$$\begin{cases} 5x + 2y = 8 \\ x - 3y = 22 \end{cases}$$

Kelly said “Oh that’s easy — you just set them equal to each other.” Looking puzzled, Wes replied “Well, I know the method of *linear combinations*, and I know the method of *substitution*, but I do not know what method you are talking about.” First, explain each of the methods to which Wes is referring, and show how they can be used to solve the system. Second, explain why Wes did not find sense in Kelly’s comment. Third, check that your answer agrees with the diagram.

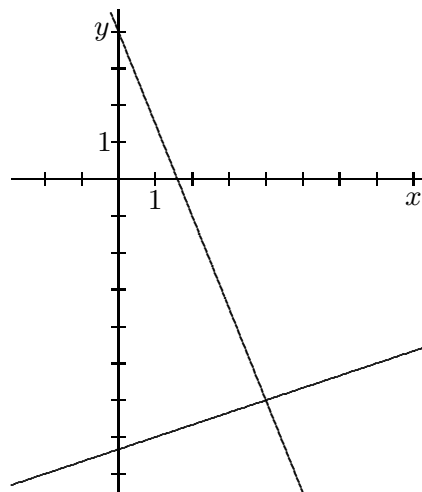

10. The owner’s manual for my computer printer states that it will print a page in 12 seconds. Re-express this speed in pages per minute, and in minutes per page.

## Mathematics 1

1. My car averages 29 miles per gallon of gasoline, but I know — after many years of fueling it — that the actual miles per gallon can vary by as much as 3 either way. Write an absolute-value inequality that describes the range of possible mpg figures for my car.
2. What algebra blocks would you need to order from the Math Warehouse so that you could build a square whose edges are all  $x + 4$  units long?
3. Shaw's carries two types of apple juice. One is 100% fruit juice, while the other is only 40% juice. Yesterday there was only one 48-ounce bottle of the 100% juice left. I bought it, along with a 32-ounce bottle of the 40% juice. I am about to mix the contents of the two bottles together. What percent of the mixture will be actual fruit juice?
4. (Continuation) On second thought, I want the mixture to be at least 80% real fruit juice. How much of the 32-ounce bottle can I add to the mixture and be satisfied?
5. Solve each of the systems of equations below
  - (a) 
$$\begin{cases} 3x + 4y = 1 \\ 4x + 8y = 12 \end{cases}$$
  - (b) 
$$\begin{cases} 2x + 3y = -1 \\ 6x - 5y = -7 \end{cases}$$
6. To run 10000 meters in a world-class time of 27:30 (27 minutes and 30 seconds), approximately what time should a competitor expect to hear at the 1600-meter mark?
7. If you have one  $x^2$ -block and two  $x$ -blocks, how many 1-blocks do you need to form a square? What are the dimensions of the square? Draw a diagram of the finished arrangement. Fill in the blanks in the equation  $x^2 + 2x + \underline{\hspace{1cm}} = (\hspace{1cm})(\hspace{1cm}) = (\hspace{1cm})^2$ .
8. Randy has 25% more money than Sandy, and 20% more money than Mandy, who has \$1800. How much money does Sandy have?

9. The diagram at the right represents a solid of uniform cross-section. All the lines of the figure meet at right angles. The dimensions are marked in the drawing in terms of  $x$ . Write simple formulas in terms of  $x$  for each of the following:

- (a) the volume of the solid;
- (b) the surface area you would have to cover in order to paint this solid;
- (c) the length of decorative cord you would need if you wanted to outline all the edges of this solid.

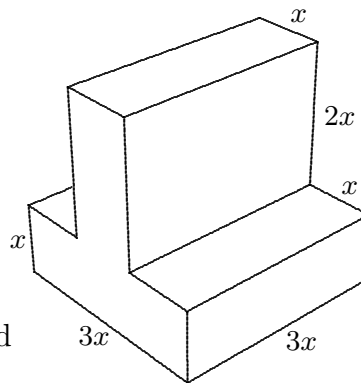

10. The average of two numbers is 41. If one of the numbers is 27, what is the other number? If the average of two numbers is  $x + y$ , and one of the numbers is  $x$ , what is the other number?
11. A restaurant has 23 tables. Some of the tables seat 4 persons and the rest seat 2 persons. In all, 76 persons can be seated at once. How many tables of each kind are there?

## Mathematics 1

1. Solve each of the following systems of equations:

$$(a) \begin{cases} 3r + 5s = 6 \\ 9r = 13s + 4 \end{cases}$$

$$(b) \begin{cases} 3a = 1 + \frac{1}{3}b \\ 5a + b = 11 \end{cases}$$

2. Use the distributive property to write each of the following in *factored form*:

$$(a) ab^2 + ac^2$$

$$(b) 3x^2 - 6x$$

$$(c) wx + wy + wz + w$$

3. Most of Conservative Casey's money was put into a savings account that paid 5% interest a year, but some of it was put into a risky stock fund that paid 16% a year. Casey's total initial investment in the two accounts was \$10000. At the end of the first year, Casey received a total of \$775 in interest from the two accounts. Find the amount invested in each.

4. Find the value of  $p$  that makes the linear graph  $y = p - 3x$  pass through the point where the lines  $4x - y = 6$  and  $2x - 5y = 12$  intersect.

5. Faced with the problem of multiplying  $5^6$  times  $5^3$ , Brook is having trouble deciding which of these four answers is correct:  $5^{18}$ ,  $5^9$ ,  $25^{18}$ , or  $25^9$ . Your help is needed. Once you have answered Brook's question, experiment with other examples of this type until you are able to formulate the *common-base principle for multiplication* of expressions  $b^m \cdot b^n$ .

6. The diagram at right shows a calculator screen, on which the lines  $5x + 4y = 32$  and  $-5x + 6y = 8$  have been graphed. What are the window specifications for this picture? In other words, the window can be described by the two inequalities  $a \leq x \leq b$  and  $c \leq y \leq d$ , using what numbers in place of  $a$ ,  $b$ ,  $c$ , and  $d$ ?

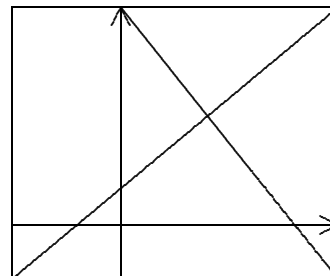

7. For the final in-class test in math this term, I am thinking of giving a 100-question true-false test! Right answers will count one point, wrong answers will deduct half a point, and questions left unanswered will have no effect. One way to get a 94 using this scoring system is to answer 96 correctly and 4 incorrectly (and leave 0 blank). Find another way of obtaining a score of 94.

8. (Continuation) Let  $r$  equal the number of right answers and  $w$  equal the number of wrong answers. Write an equation relating  $r$  and  $w$  that states that the test grade is 94. Write an inequality that states that the grade is *at least* 94, and graph it. Also graph the inequalities  $0 \leq r$ ,  $0 \leq w$ , and  $r + w \leq 100$ , and explain why they are relevant here. Shade the region that solves all four inequalities. How many lattice points does this region contain? Why is this a lattice-point problem? What is the maximum number of wrong answers one could get and still obtain a grade at least as good as 94?

9. A large family went to a restaurant for a buffet dinner. The price of the dinner was \$12 for adults and \$8 for children. If the total bill for a group of 13 persons came to \$136, how many children were in the group?

## Mathematics 1

1. Write each of the following in factored form:

(a)  $2x^2 + 3x^3 + 4x^4$

(b)  $5xp + 5x$

(c)  $2\pi r^2 + 2\pi rh$

2. Find values for  $a$  and  $b$  that make  $ax + by = 14$  parallel to  $12 - 3y = 4x$ . Is there more than one answer? If so, how are the different values for  $a$  and  $b$  related?

3. Impeded by the current, the Outing Club took 4 hours and 24 minutes to paddle 11 km up the Exeter River to their campsite last weekend. The next day, the current was with them, and it took only 2 hours to make the return trip to campus. Everyone paddled with the same intensity on both days. At what rate would the paddlers have traveled if there had been no current? What was the speed of the current?

4. Exponents are routinely encountered in scientific work, where they help investigators deal with large numbers:

(a) The human population of Earth is roughly 6000000000, which is usually expressed in *scientific notation* as  $6 \times 10^9$ . The average number of hairs on a human head is  $5 \times 10^5$ . Use scientific notation to estimate the total number of human head hairs on Earth.

(b) Light moves very fast — approximately  $3 \times 10^8$  meters every second. At that rate, how many meters does light travel in one year, which is about  $3 \times 10^7$  seconds long? This so-called *light year* is used in astronomy as a yardstick for measuring even greater distances.

5. A car went a distance of 90 km at a steady speed and returned along the same route at half that speed. The time for the whole round trip was four hours and a half. Find the two speeds.

6. Solve the equation  $1.2x + 0.8(20 - x) = 17.9$  for  $x$ . Make up a word problem that could use this equation in its solution. In other words, the equation needs a context.

7. The diagram at right shows the graphs of four lines, whose equations are  $y = 2x + 3$ ,  $x + y = 3$ ,  $4x + 3y = 24$ , and  $3x - y = 9$ .

(a) Find coordinates for the intersection point  $M$ .

(b) Write a system of simultaneous inequalities that describes the shaded region.

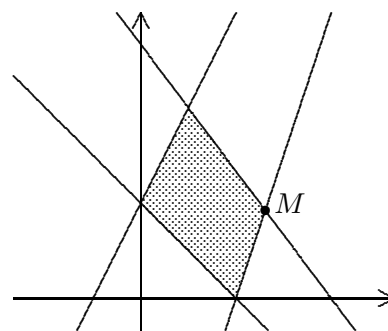

8. Write the following sentence using mathematical symbols: “The absolute value of the sum of two numbers  $a$  and  $b$  is equal to the sum of the absolute values of each of the numbers  $a$  and  $b$ .” Is this a true statement? Explain.

9. The perimeter of a square is  $p$  inches. Write expressions, in terms of  $p$ , for the length of the side of the square and the area of the square.

## Mathematics 1

1. You have one  $x^2$ -block, eight  $x$ -blocks, and an ample supply of 1-blocks. How many 1-blocks do you need to form a square? What are the dimensions of the square? Fill in the blanks in the identity  $x^2 + 8x + \underline{\hspace{1cm}} = (\hspace{1cm})(\hspace{1cm}) = (\hspace{1cm})^2$ .

2. The figure shows the graphs of two lines, whose axis intercepts are integers. Use the graphs to estimate the coordinates of the point that belongs to both lines, then calculate the exact value. You will of course have to find equations for the lines.

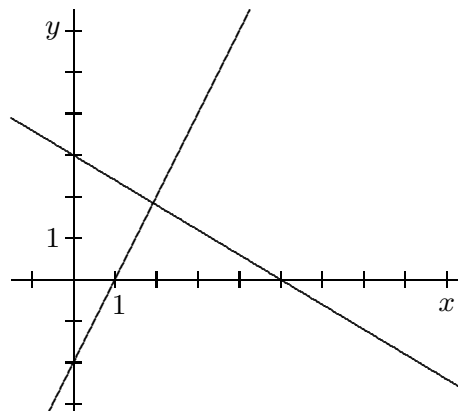

3. If it costs  $d$  dollars to buy  $p$  gizmos, how much will it cost to buy  $k$  gizmos?

4. Find three lattice points on the line  $x + 3y = 10$ . How many others are there?

5. In a coordinate plane, shade the region that consists of all points that have positive  $x$ - and  $y$ -coordinates whose sum is less than 5. Write a system of three inequalities that describes this region.

6. Suppose that  $h$  is 40% of  $p$ . What percent of  $h$  is  $p$ ?

7. Pat is the CEO of Pat's Pickle-Packing Plant, but can still pack 18 jars of pickles per hour. Kim, a rising star in the industry, packs 24 jars per hour. Kim arrived at work at 9:00 am one day, to find that Pat had been packing pickles since 7:30 am. Later that day, Kim had packed exactly the same number of jars as Pat. At what time, and how many jars had each packed?

8. A laser beam is shot from the point  $(0, 2.35)$  along the line whose slope is 3.1. Will it hit a very thin pin stuck in this coordinate plane at the point  $(10040, 31126)$ ?

9. The Exeter Tree Company charges a certain amount per cord for firewood and a fixed amount for each delivery, no matter how many cords are delivered. My bill from ETC last winter was \$155 for one cord of wood, and my neighbor's was \$215 for one and one-half cords. What is the charge for each cord of wood and what is the delivery charge?

10. A long-distance telephone call costs \$2.40 plus \$0.23 per minute. Write an inequality that states that an  $x$ -minute call costs at most \$5.00. Solve the inequality to find the maximum number of minutes that it is possible to talk without spending more than \$5.00.

11. A *monomial* is a product of variables — no additions, subtractions, or divisions — times an optional constant. If some factors occur more than once, it is customary to use exponents to consolidate them. Thus  $3ax^2$  and  $x^5$  are monomials, but  $3xy^4 + 3x^4y$  is not. Rewrite each of these as a monomial:

(a)  $x \cdot x^2 \cdot x^3 \cdot x^4$

(b)  $3a^4 \cdot 5a^6$

(c)  $(2x)^7$

(d)  $(\frac{2}{3}w)^3 \cdot 5w^3$

## Mathematics 1

1. The point  $(2, 3)$  lies on the line  $2x + ky = 19$ . Find the value of  $k$ .
2. Taylor works after school in a health-food store, where one of the more challenging tasks is to add cranberry juice to apple juice to make a cranapple drink. A liter of apple juice costs \$0.85 and a liter of cranberry juice costs \$1.25. The mixture is to be sold for exactly the cost of the ingredients, at \$1.09 per liter. How many liters of each juice should Taylor use to make 20 liters of the cranapple mixture?
3. Do the three lines  $5x - y = 7$ ,  $x + 3y = 11$ , and  $2x + 3y = 13$  have a common point of intersection? If so, find it. If not, explain why not.
4. Using an absolute-value inequality, describe the set of numbers whose distance from 4 is greater than 5 units. Draw a graph of this set on a number line. Finally, describe this set of numbers using inequalities without absolute value signs.
5. Calculate the area of the region defined by the simultaneous inequalities  $y \geq x - 4$ ,  $y \leq 10$ , and  $5 \leq x + y$ .
6. Cameron can spend at most 2 hours on math and biology homework tonight. Biology reading always takes at least 45 minutes, but, because there is also a math hand-in due tomorrow, Cameron knows that math is going to require more time than biology.
  - (a) Using the variables  $m$  and  $b$ , express the constraints on Cameron's study time by a system of inequalities. Work in minutes.
  - (b) Graph the inequalities with  $m$  on the horizontal axis and  $b$  on the vertical axis, and highlight the region that satisfies all three inequalities. Such a region is called a *feasible region*, because every point in the region is a possible (feasible) solution to the system.
  - (c) Is the point  $(60, 50)$  in the feasible region?
7. A *polynomial* is obtained by adding (or subtracting) monomials. Use the distributive property to rewrite each of the following polynomials in factored form. In each example, you will be *finding a common monomial factor*.
  - (a)  $x^2 - 2x$
  - (b)  $6x^2 + 21x$
  - (c)  $80t - 16t^2$
  - (d)  $9x^4 - 3x^3 + 12x^2 - x$A *binomial* is the sum of two unlike monomials, and a *trinomial* is the sum of three unlike monomials. The monomials that make up a polynomial are often called its *terms*.
8. The simultaneous conditions  $x - y < 6$ ,  $x + y < 6$ , and  $x > 0$  define a region  $\mathcal{R}$ . How many lattice points are contained in  $\mathcal{R}$ ?
9. In  $7^4 \cdot 7^4 \cdot 7^4 = (7^4)^\Delta$  and  $b^9 \cdot b^9 \cdot b^9 \cdot b^9 = (b^9)^\nabla$ , replace the triangles by correct exponents. The expression  $(p^5)^6$  means to write  $p^5$  as a factor how many times? To rewrite this expression without exponents as  $p \cdot p \cdot p \cdots$ , how many factors would you need?
10. Graph the system of equations shown at right. What special relationship exists between the two lines? Confirm this by solving the equations algebraically.
$$\begin{cases} 3x - y = 10 \\ 6x = 20 + 2y \end{cases}$$



## Mathematics 1

1. Population data for Vermont is given in the table at right.

<i>year</i>	<i>pop</i>
1960	389881
1970	448327
1980	511456
1990	564964
2000	609890

(a) Find the average annual growth rate of this population during the time interval from 1960 to 2000.

(b) Write an equation for a line in point-slope form, using the ordered pair (1960, 389881) and the slope you found in part (a).

(c) Evaluate your equation for the years 1970 and 1980, and notice that these *interpolated* values do not agree with the actual table values. Find the size of each error, expressed as a percent of the actual population value.

(d) Use your point-slope equation to *extrapolate* a population prediction for 2010.

(e) New Hampshire has roughly the same area as Vermont, but its population reached one million a few years ago. Predict when this will happen to Vermont's population.

2. The cooling system of Alex's car holds 10 quarts. It is now filled with a mixture that is 60% water and 40% antifreeze. Hearing a weather forecast for severe cold, Alex decides to increase the strength of the antifreeze mixture to 50%. To do this, Alex must drain off a certain number of quarts from the cooling system and then replace them by pure antifreeze. How many quarts must be drained?

3. Faced with the problem of calculating  $(5^4)^3$ , Brook is having trouble deciding which of these three answers is correct:  $5^{64}$ ,  $5^{12}$ , or  $5^7$ . Once you have answered Brook's question, experiment with other examples of this type until you are ready to formulate the principle that tells how to write  $(b^m)^n$  as a power of  $b$ .

4. The diameter of an atom is so small that it would take about  $10^8$  of them, arranged in a line, to span one centimeter. It is thus a plausible estimate that a cubic centimeter contains about  $10^8 \times 10^8 \times 10^8 = (10^8)^3$  atoms. Write this huge number as a power of 10.

5. Blair runs a kiosk at the local mall that sells sweatshirts. There are two types of shirts sold. One is 100% cotton, on which the markup is \$6 per shirt. The other is a cotton and polyester blend, on which the markup is \$4 per shirt. It costs Blair \$900 per month to rent the kiosk. Let  $c$  represent the number of pure cotton sweatshirts sold in one month and  $b$  the number of blended sweatshirts sold in the same month.

(a) In terms of  $c$  and  $b$ , write an inequality that states that Blair's sales will at least meet the monthly rental expense. Sketch a graph.

(b) This month, Blair could only get 20 of the pure cotton shirts from the distributor. This adds another constraint to the system. How does it affect the graph you drew in (a)?

6. On the *same axes*, sketch the graphs of  $y = |x - 3|$  and  $y = 4 - |x - 3|$ . Label the points of intersection with coordinates. Find the area enclosed.

7. During a phone call about the system of equations  $\{5x + 2y = 8, 8x + 4y = 8\}$ , Dylan told Max, "It's easy, just set them equal to each other." But Max replied, "That doesn't help — I get  $-2y = 3x$ . What good is that?" Help these two students solve the problem.

## Mathematics 1

1. A math teacher is designing a test, and wants  $(3, -4)$  to be the solution to the system of equations  $\{3x - 5y = a, 7x + y = b\}$ . What values should the teacher use for  $a$  and  $b$ ?

2. The figure at right shows the graphs of two lines. Use the figure to estimate the coordinates of the point that belongs to both lines, then calculate the exact value. You will of course have to find equations for the lines, which both go through designated lattice points.

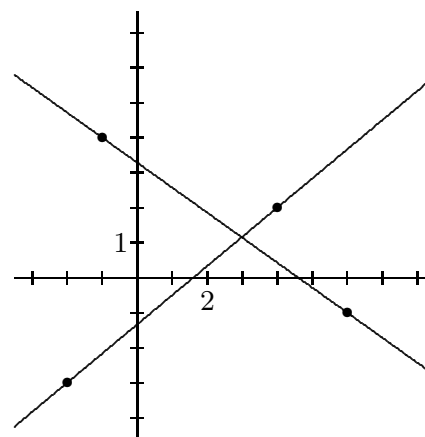

3. Graph the equation  $|x| + |y| = 6$ . Notice that the graph has several vertices. Shade the region described by  $|x| + |y| \leq 6$ .

4. A square can be formed from one  $x^2$ -block, a hundred  $x$ -blocks and a certain number of 1-blocks. How many 1-blocks? Show how to do it. What are the dimensions of the square? Fill in the blanks in the equation  $x^2 + 100x + \underline{\hspace{1cm}} = (\hspace{1cm})(\hspace{1cm}) = (\hspace{1cm})^2$ .

5. The figure shows a loading dock and a side view of an attached ramp, whose run is 12 feet and whose rise is 39 inches. Alex is wondering whether a long rectangular box can be stored underneath the ramp, as suggested by the dotted lines. The box is 2 feet tall and 5 feet long. Answer Alex's question.

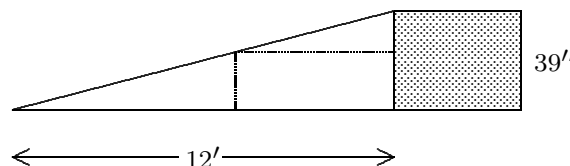

6. Solve the system  $\{ax + ky = 1, 2ax - ky = 8\}$  for  $x$  and  $y$  in terms of  $a$  and  $k$ .

7. Lee spent  $c$  cents to buy five pears. In terms of  $c$  and  $d$ , how many pears could Lee have bought with  $d$  dollars?

8. Find  $k$  so that the three equations  $3x - y = 2$ ,  $2x + 8 = 3y$ , and  $y = kx$  have a common solution.

9. A catering company offers three monthly meal contracts:

Contract  $A$  costs a flat fee of \$480 per month for 90 meals;

Contract  $B$  costs \$200 per month plus \$4 per meal;

Contract  $C$  costs a straight \$8 per meal.

If you expect to eat only 56 of the available meals in a month, which contract would be best for you? When might someone prefer contract A? contract B? contract C?

10. Graph the equation  $|x + y| = 1$ . Shade the region described by  $|x + y| \leq 1$ .

11. Let  $n$  be a positive integer, and let  $\mathcal{R}$  be the region defined by the simultaneous conditions  $x - y < n$ ,  $x + y < n$ , and  $x > 0$ . In terms of  $n$ , how many lattice points are contained in  $\mathcal{R}$ ?

## Mathematics 1

1. Sandy can saw three cords of wood in a standard workday, if the whole day is spent doing it. Sandy can split five cords of wood in a standard workday, if the whole day is spent doing it. In a standard workday, what is the largest number of cords of wood that Sandy can saw *and* split?

2. Sid's summer job is working at a roadside stand that specializes in homemade ice cream. The manager asks Sid to order some small plain cones and some extra-large sugar cones. The storage room will hold at most 12 boxes of cones. A box of small plain cones cost \$30 and a box of extra-large sugar cones cost \$90 dollars. A maximum of \$800 is budgeted for this purchase of cones.

(a) Using  $p$  for the number of boxes of plain cones and  $s$  for the number of boxes of sugar cones, translate the conditions of the problem into a system of inequalities.

(b) Graph this system of inequalities and shade the feasible region for this problem. Identify the vertices of the region by specifying their coordinates.

3. You have one  $x^2$ -block and  $2n$   $x$ -blocks, where  $n$  is a positive whole number. How many 1-blocks do you need to make a square? What are the dimensions of the square? Fill in the blanks in the equation  $x^2 + 2nx + \underline{\hspace{1cm}} = (\hspace{1cm})(\hspace{1cm}) = (\hspace{1cm})^2$ .

4. You are buying some cans of juice and some cans of soda for the dorm. The juice is \$0.60 per can while the soda is \$0.75. You have \$24 of dorm funds, all to be spent.

(a) Write an equation that represents all the different combinations of juice and soda you can buy for \$24.

(b) Is it possible to buy exactly 24 cans of juice and spend the remainder on soda? Explain.

(c) How many different combinations of drinks *are* possible?

5. Jan had the same summer job for the years 1993 through 1996, earning \$250 in 1993, \$325 in 1994, \$400 in 1995, and \$475 in 1996.

(a) Plot the four data points, using the horizontal axis for "year". You should be able to draw a line through the four points.

(b) What is the slope of this line? What does it represent?

(c) Which points on this line are meaningful in this context?

(d) Guess what Jan's earnings were for 1992 and 1998, assuming the same summer job.

(e) Write an inequality that states that Jan's earnings in 1998 were within 10% of the amount you guessed.

6. Now that you have dealt with systems of two-variable equations, you can apply the same principles to solve systems of three-variable equations. For example, you can (temporarily) eliminate  $y$  in the system at right: Add the first two equations, and then add the second two equations. This produces two new equations. Find  $x$ ,  $z$ , and  $y$  to complete the solution.

$$\begin{cases} x + y + z = 2 \\ x - y + z = 6 \\ x + y - 3z = 0 \end{cases}$$

7. Replace the triangles in  $\frac{x \cdot x \cdot x \cdot x \cdot x \cdot x \cdot x}{x \cdot x \cdot x \cdot x} = x^\Delta$  and  $\frac{6^9}{6^4} = 6^\nabla$  by correct exponents.

## Mathematics 1

1. Rewrite each of the following polynomials as a product of two factors. One of the factors should be the greatest common monomial factor.

(a)  $24x^2 + 48x + 72$                       (b)  $\pi r^2 + \pi r e$                       (c)  $7m - 14m^2 + 21m^3$

2. If possible, find values for  $x$  and  $y$  for which

(a)  $|x + y| < |x| + |y|$                       (b)  $|x + y| = |x| + |y|$                       (c)  $|x| + |y| < |x + y|$

Write two *conjectures* about the relative values of  $|x| + |y|$  and  $|x + y|$ .

3. *A number trick.* Arrange the nonnegative integers into seven infinite columns, as shown in the table at right. Without telling you what they are, someone selects two numbers, one from the 2-column (the column that contains 2) and one from the 5-column, and multiplies them. You predict the column in which the answer will be found. How?

0	1	2	3	4	5	6
7	8	9	10	11	12	13
14	15	16	17	18	19	20
21	22	23	24	25	26	27
28	29	30	31	32	33	34
35	36	37	38	39	40	41
:	:	:	:	:	:	:

4. To make a little spending money, Taylor decided to sell special souvenir programs for the Exeter-Andover wrestling match. The printing cost was \$0.32 per program, and they were priced at \$0.50 each. Taylor sold all but 50 of the programs, and made a small profit of \$11. How many programs were printed?

5. Chet has at most 20 hours a week available to work during the summer, dividing that time between making \$3 an hour babysitting and \$7 an hour working for a landscaping company. Chet needs to accumulate at least \$84 per week.

(a) Write a system of inequalities that describes the given conditions.

(b) What are the most hours Chet can work babysitting and still earn at least \$84?

6. Refer to the diagram at right, which shows a large square that has been subdivided into two squares and two rectangles. Write formulas for the areas of these four pieces, using the dimensions  $a$  and  $b$  marked on the diagram. Then write an equation that states that the area of the large square is equal to the combined area of its four pieces. Do you recognize this equation?

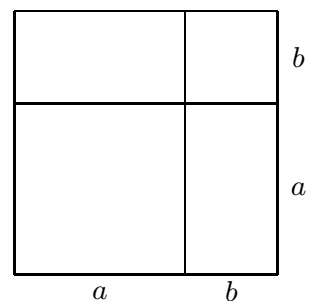

7. Find coordinates for the point where the line  $3x - 2y = 3001$  intersects the line  $4x - 3y = 4001$ . First solve the problem without using your calculator, then confirm your answer using your calculator.

8. Find the equations of at least three lines that intersect each other at the point  $(6, -2)$ .

9. Driving along Route 108 one day, a math teacher reached the railroad crossing in Newmarket at exactly the same time as a long freight train. While waiting patiently for the caboose to finally arrive and pass, the teacher decided to estimate the length of the train, which seemed to be moving at about 10 miles per hour. Given that it was a five-minute wait, how many feet did the teacher estimate the length of the train to be?

## Mathematics 1

- Find coordinates for the point of intersection of the lines  $px + y = 1$  and  $3px + 2y = 4$ . You will have to express your answer in terms of  $p$ .
- Robin works part-time carving wooden seagulls and lobsters to sell to tourists during the summer season. Keeping up with demand means carving at least two seagulls and three lobsters a day. Robin can produce at most a dozen models a day.
  - Using  $x$  for the number of seagulls and  $y$  for the number of lobsters, write three inequalities that describe Robin's daily limitations. Graph the feasible region.
  - In June, each seagull model brought a \$6 profit and each lobster model brought a \$4 profit. Write an expression for Robin's total profit on  $x$  seagulls and  $y$  lobsters.
  - Draw on your graph the line that states that Robin's profit is \$48. Do all the points on this line have meaning in this context? Which combinations of seagulls and lobsters produce a profit of exactly \$48?
- (Continuation) Can Robin make a profit of \$70 in one day? What combination of seagulls and lobsters produces the greatest daily profit? What is this maximum profit?
- (Continuation) The economics of tourist trinkets is volatile. In August, Robin found that the seagull profit had dipped to \$4, while the lobster profit had soared to \$5.
  - Is it now possible for Robin to make a profit of \$55 per day?
  - What is the greatest profit Robin can make in one day?
- Factor the following: (a)  $2x^2 - 4x$       (b)  $x^2 + 24x + 144$       (c)  $x^2 + 3x$
- Pat and Kim are in the habit of taking a morning coffee break in the Grill. Each of them arrives at a random time between 9 am and 10 am, and stays for exactly ten minutes.
  - If Kim arrives at Grill at 9:37 tomorrow, what arrival times for Pat allow the two to see each other during their breaks?
  - Suppose that Pat and Kim arrive at  $p$  minutes and  $k$  minutes after 9 am, respectively. Find values for  $p$  and  $k$  that signify that one person is arriving just as the other is leaving.
  - Shade those points  $(p, k)$  in the coordinate plane that signify that Pat and Kim see each other at some time during their breaks.
- Faced with the problem of dividing  $5^{24}$  by  $5^8$ , Brook is having trouble deciding which of these four answers is correct:  $5^{16}$ ,  $5^3$ ,  $1^{16}$ , or  $1^3$ . Your help is needed. Once you have answered Brook's question, experiment with other examples of this type until you are ready to formulate the *common-base principle for division* that tells how to divide  $b^m$  by  $b^n$  and get another power of  $b$ . Then apply this principle to the following situations:
  - Earth's human population is roughly  $6 \times 10^9$ , and its total land area, excluding the polar caps, is roughly  $5 \times 10^7$  square miles. If the human population were distributed uniformly over all available land, approximately how many persons would be found per square mile?
  - At the speed of light, which is  $3 \times 10^8$  meters per second, how many seconds does it take for the Sun's light to travel the  $1.5 \times 10^{11}$  meters to Earth?

## Mathematics 1

1. Cameron just bought some 39-cent, 24-cent, and 13-cent stamps at the Post Office. The 100 stamps cost \$33.40, and there were twice as many 24-cent stamps in the sale as there were 13-cent stamps. How many stamps of each denomination did Cameron buy?
2. Given the equation  $3x + y = 6$ , write a second equation that, together with the first, will create a system of equations that
  - (a) has one solution;
  - (b) has an infinite number of solutions;
  - (c) has no solution;
  - (d) has the ordered pair  $(4, -6)$  as its only solution.
3. At noon, a team bus left Exeter for Deerfield. Soon thereafter, PEA's first-line player Brett Starr arrived at the gym. A loyal day student volunteered to overtake the bus and deliver Brett. The two left at 12:15 pm. The day student drove at 54 mph, while ahead of them the ancient yellow bus poked along at 48 mph. Did the car catch the bus before it reached Deerfield, which is 110 miles from Exeter? If so, where and when?
4. Factor the following *perfect-square trinomials*:
  - (a)  $x^2 - 12x + 36$
  - (b)  $x^2 + 14x + 49$
  - (c)  $x^2 - 20x + 100$As suggested, these should all look like either  $(x - r)^2$  or  $(x + r)^2$ . State the important connection between the *coefficients* of the given trinomials and the values you found for  $r$ .
5. (Continuation) In the following, choose  $k$  to create a perfect-square trinomial:
  - (a)  $x^2 - 16x + k$
  - (b)  $x^2 + 10x + k$
  - (c)  $x^2 - 5x + k$
6. In each of the following, find the correct value for  $\nabla$ :
  - (a)  $y^4 y^7 = y^\nabla$
  - (b)  $y^{12} y^\nabla = y^{36}$
  - (c)  $y^4 y^4 y^4 y^4 = y^\nabla$
  - (d)  $(y^\nabla)^3 = y^{27}$
7. There are 55 ways to make  $x^\heartsuit x^\diamondsuit x^\clubsuit = x^{12}$  an identity, by assigning positive integers to the heart, diamond, and club. Find four of them.
8. According to the US Census Bureau, the population of the USA has a net gain of 1 person every 14 seconds. How many additional persons does that amount to in one year?
9. Find three consecutive odd numbers whose sum is 627.
10. Graph  $y = \frac{2}{3}|x - 5| - 3$ .
  - (a) What are the coordinates of the vertex of this graph?
  - (b) Find the coordinates of the two  $x$ -intercepts of the graph.
  - (c) Using each of these points and the vertex, compute the slope of each side of the graph. How are these slopes related?

## Mathematics 1

1. The distance from here to the beach at Little Boar's Head is 10 miles. If you walked there at 4 mph and returned jogging at 8 mph, how much time would the round trip take? What would your overall average speed be?

2. The diagram at right shows a rectangle that has been cut into eleven square pieces, no two being the same size. Given that the smallest piece is 9 cm by 9 cm, figure out the sizes of the other ten pieces. The original rectangle also looks like it could be square. Is it?

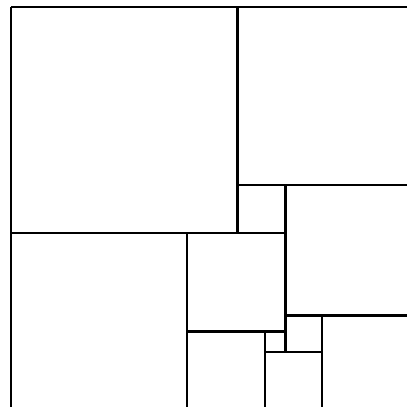

3. Given that three shirts cost  $d$  dollars,  
(a) How many dollars does one shirt cost?  
(b) How many dollars do  $k$  shirts cost?  
(c) How many shirts can be bought with  $q$  quarters?

4. It would take Tom 8 hours to whitewash the fence in the backyard. His friend Huck would need 12 hours to do the same job by himself. They both start work at 9 in the morning, each at opposite ends of the fence, under the watchful eye of Tom's Aunt Polly. At what time in the afternoon is the task complete?

5. Jess is running around a circular track, one lap every 40 seconds. Cameron is also running at a constant speed around the same track, but in the opposite direction. They meet every 15 seconds. How many seconds does it take Cameron to do one lap?

6. Ten cc of a solution of acid and water is 30% acid. I wish to dilute the acid in the mixture by adding water to make a mixture that is only 6% acid. How much pure water must I add to accomplish this?

7. Corey is out on the roads doing a long run, and also doing some mental calculations at the same time. Corey's pace is 3 strides per second, and each stride covers 5 feet.

(a) How much time does it take Corey to cover a mile?  
(b) If Corey's stride increased to 5.5 feet per step, how much time would be needed to cover a mile?  
(c) At five feet per step, how many steps would Corey need to run the marathon distance, which is 26 miles and 385 yards?

8. What are the dimensions of a square that encloses the same area as a rectangle that is two miles long and one mile wide? Answer to the nearest inch, please.

## Mathematics 1

1. When I ask my calculator for a decimal value of  $\sqrt{2}$ , it displays 1.41421356237. What is the meaning of this number? To check whether this square root is correct, what needs to be done? Can the square root of 2 be expressed as a ratio of whole numbers — for example as  $\frac{17}{12}$ ? Before you say “impossible”, consider the ratio  $\frac{665857}{470832}$ .
2. What happens if you try to find an intersection point for the linear graphs  $3x - 2y = 10$  and  $3x - 2y = -6$ ? What does this mean?
3. A jeweler has 10 ounces of an alloy that is 50% gold. How much more pure gold does the jeweler need to add to this alloy, to increase the percentage of gold to 60%?
4. Evaluate  $6 - 4/2 + 2 \cdot 5$  and then check using your calculator. Show how the insertion of parentheses can make the value of the expression equal to **(a)** 1 **(b)**  $-14$  **(c)** 25
5. When an object falls, it gains speed. Thus the number of feet  $d$  the object has fallen is not linearly related to the number of seconds  $t$  spent falling. In fact, for objects falling near the surface of the Earth, with negligible resistance from the air,  $d = 16t^2$ . How many seconds would it take for a cannonball to reach the ground if it were dropped from the top of the Eiffel Tower, which is 984 feet tall? How many seconds would it take for the cannonball to reach the ground if it were dropped from a point that is halfway to the top?
6. The Exeter Bookcase Company makes two types of bookcase, pine and oak. The EBC produces at least 30 but no more than 45 bookcases each week. They always build more pine bookcases than oak and they make at least five oak bookcases per week. Let  $x$  and  $y$  denote the weekly production of oak bookcases and pine bookcases, respectively, and write a system of inequalities that models this situation. Graph the inequalities and shade the feasible region. Given that  $x$  and  $y$  are discrete variables, are all the shaded points meaningful?
7. (Continuation) Because oak is heavier than pine, the costs of packing and shipping are \$25 for an oak bookcase and only \$15 for a pine bookcase.
  - (a) What combination of bookcases will cost a total of \$700 to pack and ship?
  - (b) Can the packing and shipping costs be reduced to \$450?
  - (c) What combination of bookcases will make the packing and shipping costs as small as possible?
8. Pat and Kim are having an algebra argument. Kim is sure that  $-x^2$  is equivalent to  $(-x)^2$ , but Pat thinks otherwise. How would you resolve this disagreement? What evidence does your calculator offer?
9. Given that Brett can wash  $d$  dishes in  $h$  hours, write expressions for
  - (a) the number of hours it takes for Brett to wash  $p$  dishes;
  - (b) the number of dishes Brett can wash in  $y$  hours;
  - (c) the number of dishes Brett can wash in  $m$  minutes.



## Mathematics 1

1. What is the value of  $\frac{5^7}{5^7}$ ? of  $\frac{8^3}{8^3}$ ? of  $\frac{c^{12}}{c^{12}}$ ? What is the value of any number divided by itself? If you apply the common-base rule dealing with exponents and division,  $\frac{5^7}{5^7}$  should equal 5 raised to what power? and  $\frac{c^{12}}{c^{12}}$  should equal  $c$  raised to what power? It therefore makes sense to define  $c^0$  to be what?

2. If  $\sqrt{2}$  can be expressed as a ratio  $\frac{m}{n}$  of two whole numbers, then this fraction can be put in lowest terms. Assume that this has been done.

(a) Square both sides of the equation  $\sqrt{2} = \frac{m}{n}$ .

(b) Multiply both sides of the new equation by  $n^2$ . The resulting equation tells you that  $m$  must be an even number. Explain.

(c) Because  $m$  is even, its square is divisible by 4. Explain.

(d) It follows that  $n^2$  is even, hence so is  $n$ . Explain.

(e) Thus both  $m$  and  $n$  are even. Explain why is this a contradictory situation.

A number expressible as a ratio of whole numbers is called *rational*. All other numbers, such as  $\sqrt{2}$ , are called *irrational*.

3. An avid gardener, Gerry Anium just bought 80 feet of decorative fencing, to create a border around a new rectangular garden that is still being designed.

(a) If the width of the rectangle were 5 feet, what would the length be? How much area would the rectangle enclose? Write this data in the first row of the table.

(b) Record data for the next five examples in the table.

(c) Let  $x$  be the width of the garden. In terms of  $x$ , fill in the last row of the table.

<i>width</i>	<i>length</i>	<i>area</i>
5		
9		
16		
22		
24		
35		
$x$		

(d) Use your calculator to graph the rectangle's area versus  $x$ , for  $0 \leq x \leq 40$ . As a check, you can make a scatter plot using the table data. What is special about the values  $x = 0$  and  $x = 40$ ?

(e) Comment on the symmetric appearance of the graph. Why was it predictable?

(f) Find the point on the graph that corresponds to the largest rectangular area that Gerry can enclose using the 80 feet of available fencing. This point is called the *vertex*.

4. One morning, Ryan remembered lending a friend a bicycle. After breakfast, Ryan walked over to the friend's house at 3 miles per hour, and rode the bike back home at 7 miles per hour, using the same route both ways. The round trip took 1.75 hours. What distance did Ryan walk?

## Mathematics 1

1. Write the following monomials without using parentheses:

(a)  $(ab)^2 (ab^2)$     (b)  $(-2xy^4) (4x^2y^3)$     (c)  $(-w^3x^2) (-3w)$     (d)  $(7p^2q^3r) (7pqr^4)^2$

2. Complete the table at right. Then graph by hand on separate axes  $y = |x|$  and  $y = x^2$ . Check your graphs with your calculator. In what respects are the two graphs similar? In what respects do the two graphs differ?

$x$	$ x $	$x^2$
-2		
-1		
-1/2		
0		
1/2		
1		
2		

3. Taylor starts a trip to the mall with \$160 cash. After 20% of it is spent, seven-eighths of the remainder is lost to a pickpocket. This leaves Taylor with how much money?

4. A worker accidentally drops a hammer from the scaffolding of a tall building. The worker is 300 feet above the ground. As you answer the following, recall that an object falls  $16t^2$  feet in  $t$  seconds (assuming negligible air resistance).

(a) How far above the ground is the hammer after falling for one second? for two seconds? Write a formula that expresses the height  $h$  of the hammer after it has fallen for  $t$  seconds.

(b) How many seconds does it take the hammer to reach the ground? How many seconds does it take for the hammer to fall until it is 100 feet above the ground?

(c) By plotting some data points and connecting the dots, sketch a graph of  $h$  versus  $t$ . Notice that your graph is *not* a picture of the path followed by the falling hammer.

5. A box with a square base and rectangular sides is to be 2 feet and 6 inches high, and to contain 25.6 cubic feet. What is the length of one edge of the square base?

6. Equations such as  $A = 40x - x^2$  and  $h = 300 - 16t^2$  define *quadratic functions*. The word *function* means that assigning a value to one of the variables ( $x$  or  $t$ ) determines a *unique* value for the other ( $A$  or  $h$ ). It is customary to say that “ $A$  is a function of  $x$ .” In this example, however, it would be incorrect to say that “ $x$  is a function of  $A$ .” Explain.

7. The graph of a quadratic function is called a *parabola*. This shape is common to all graphs of equations of the form  $y = ax^2 + bx + c$ , where  $a$  is nonzero. Confirm this by comparing the graph of  $y = x^2$ , the graph of  $y = 40x - x^2$  and the graph of  $y = 300 - 16x^2$ . How are the three graphs alike, and how are they different? Find numbers  $a$ ,  $b$ ,  $c$ , and  $d$ , so that the significant features of all three graphs fit in the window described by  $a \leq x \leq b$  and  $c \leq y \leq d$ .

8. Give two examples of linear functions. Why are they called *linear*?

9. Water pressure varies directly with the depth of submersion. Given that a diver experiences 64 pounds per square inch of pressure at a depth of 100 feet, what pressure will a submarine encounter when it is one mile below the surface of the Atlantic Ocean?

## Mathematics 1

1. From the tombstone of Diophantus, a famous Greek mathematician: “God granted him to be a boy for a sixth part of his life, and, adding a twelfth part to this, He clothed his cheeks with down. He lit him the light of wedlock after a seventh part, and five years after this marriage He granted him a son. Alas! late-born wretched child — after attaining the measure of half his father’s life, chill Fate took him. After consoling his grief by his science of numbers for four more years, then did Diophantus end his life.” Calculate how old Diophantus lived to be.

2. Factor each of the following quadratic expressions:

(a)  $x^2 + 4x$                       (b)  $2x^2 - 6x$                       (c)  $3x^2 - 15x$                       (d)  $-2x^2 - 7x$

3. (Continuation) The *zero-product property* says that  $a \cdot b = 0$  is true if  $a = 0$  or  $b = 0$  is true, and *only* if  $a = 0$  or  $b = 0$  is true. Explain this property in your own words (looking up the word *or* in the Reference section if necessary). Apply it to solve these equations:

(a)  $x^2 + 4x = 0$                       (b)  $2x^2 - 6x = 0$                       (c)  $3x^2 - 15x = 0$                       (d)  $-2x^2 - 7x = 0$

4. (Continuation) Find the  $x$ -intercepts of each of the following quadratic graphs:

(a)  $y = x^2 + 4x$                       (b)  $y = 2x^2 - 6x$                       (c)  $y = 3x^2 - 15x$                       (d)  $y = -2x^2 - 7x$

Summarize by describing how to find the  $x$ -intercepts of any quadratic graph  $y = ax^2 + bx$ .

5. When two rational numbers are multiplied together, their product is also a rational number. Explain. Is it necessarily true that the product of two irrational numbers is irrational? Explain. In some cases, the product of two irrationals has a predictable value. For each of the following, guess what the product will be, then confirm your guess with the help of your calculator.

(a)  $\sqrt{3} \cdot \sqrt{27}$                       (b)  $\sqrt{2} \cdot \sqrt{6} \cdot \sqrt{3}$                       (c)  $\sqrt{6} \cdot \sqrt{12}$                       (d)  $(\sqrt{6})^3$                       (e)  $\sqrt{3} \cdot (\sqrt{3})^2$

6. You have seen a demonstration that  $\sqrt{2}$  is irrational. Give a similar demonstration that  $\sqrt{3}$  is irrational.

7. *Golf math I.* Using a driver on the 7<sup>th</sup> tee, Dale hits an excellent shot, right down the middle of the level fairway. The ball follows the parabolic path shown in the figure, described by the quadratic function  $y = 0.5x - 0.002x^2$ . This relates the height  $y$  of the ball above the ground to the ball’s progress  $x$  down the fairway. Distances are measured in yards.

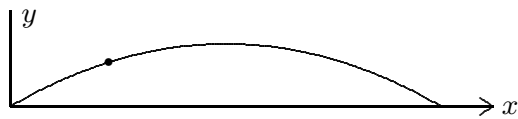

(a) Use the distributive property to write this equation in factored form. Notice that  $y = 0$  when  $x = 0$ . What is the significance of this data?

(b) How far from the tee does the ball hit the ground?

(c) At what distance  $x$  does the ball reach the highest point of its arc? What is the maximal height attained by the ball?

## Mathematics 1

1. The manager of the Stratham Flower Shop is ordering potted lilies and tulips from a local wholesaler. Per pot, the lilies cost \$3 and the tulips cost \$2. Storage space at the shop requires that the order be no more than 120 pots total. The manager knows from previous experience that at least 30 of each type are needed, and that the number of lilies should be at most two thirds of the number of tulips.

(a) Sketch the feasible region that satisfies the above conditions.

(b) The manager sells lilies for \$5 a pot, and tulips for \$3.50 a pot. Calculate the profit earned at each corner of the feasible region.

2. Evaluate each of the following expressions by *substituting*  $s = 30$  and  $t = -4$ .

(a)  $t^2 + 5t + s$       (b)  $2t^2s$       (c)  $3t^2 - 6t - 2s$       (d)  $s - 0.5t^2$

3. There are several positive integers that leave a remainder of 12 when they are divided into 192. Find the smallest and the largest of those integers.

4. A Prep set out to bicycle from Exeter to the beach, a distance of 10 miles. After going a short while at 15 miles per hour, the bike developed a flat tire, and the trip had to be given up. The walk back to Exeter was made at a dejected 3 miles per hour. The whole episode took 48 minutes. How many miles from Exeter did the flat occur?

5. A car traveling at 60 miles per hour is covering how many feet in one second? A football field is 100 yards long. At 60 mph, how many seconds does it take to cover this distance? State your answer to the nearest tenth of a second.

6. Perform the indicated operations, and record your observations:

(a)  $\sqrt{2} \cdot \sqrt{18}$       (b)  $\sqrt{8} \cdot \sqrt{8}$       (c)  $2\sqrt{5} \cdot 3\sqrt{20}$

Suggest a rule for multiplying numbers in the form  $\sqrt{a} \cdot \sqrt{b}$ . Extend your rule to problems in the form of  $p\sqrt{a} \cdot q\sqrt{b}$ .

7. (Continuation) Use what you have just seen to explain why  $\sqrt{20} = \sqrt{4} \cdot \sqrt{5} = 2\sqrt{5}$ . Rewrite the following square roots in the same way — as the product of a whole number and a square root of an integer *that has no perfect square factors*. The resulting expression is said to be in *simplest radical form*.

(a)  $\sqrt{50}$       (b)  $\sqrt{108}$       (c)  $\sqrt{125}$       (d)  $\sqrt{128}$

8. Taylor has enough money to buy either 90 granola bars or 78 pop-tarts. After returning from the store, Taylor has no money, 75 granola bars, and  $p$  pop-tarts. Assuming that Taylor has not yet eaten anything, figure out what  $p$  is.

9. Avery and Alden were comparing parabola graphs on their calculators. Avery had drawn  $y = 0.001x^2$  in the window  $-1000 \leq x \leq 1000$  and  $0 \leq y \leq 1000$ , and Alden had drawn  $y = x^2$  in the window  $-k \leq x \leq k$  and  $0 \leq y \leq k$ . Except for scale markings on the axes, the graphs looked exactly the same! What was the value of  $k$ ?

## Mathematics 1

1. At Sam's Warehouse, a member pays \$25 a year for membership, and buys at the regular store prices. A non-member does not pay the membership fee, but does pay an additional 5% above the store prices. Under what conditions would it make sense to buy a membership?

2. Sketch the graphs of  $y = x^2 + 5$ ,  $y = x^2 - 4$ , and  $y = x^2 + 1$  on the same axes. What is the effect of the value of  $c$  in equations of the form  $y = x^2 + c$ ?

3. *Golf math II.* Again using a driver on the 8<sup>th</sup> tee, which is on a plateau 10 yards above the level fairway, Dale hits another fine shot. Explain why the quadratic function  $y = 10.0 + 0.5x - 0.002x^2$  describes this parabolic trajectory, shown in the figure above. Why should you expect this tee shot to go more than 250 yards? Estimate the length of this shot, then use your calculator to find a more accurate value. How does this trajectory relate to the trajectory for the drive on the previous hole?

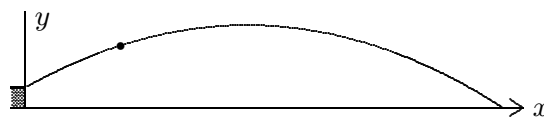

4. (Continuation) To find the length of the shot without a calculator, you must set  $y$  equal to 0 and solve for  $x$ . Explain why, and show how to arrive at  $x^2 - 250x = 5000$ .

(a) The next step in the solution process is to add  $125^2$  to both sides of this equation. Why was this number chosen?

(b) Complete the solution by showing that the length of the shot is  $125 + \sqrt{20625}$ . How does this number, which is about 268.6, compare with your previous calculation?

(c) Comment on the presence of the number 125 in the answer. What is its significance?

5. Graph the equations on the same system of axes:  $y = x^2$ ,  $y = 0.5x^2$ ,  $y = 2x^2$ , and  $y = -x^2$ . What is the effect of  $a$  in equations of the form  $y = ax^2$ ?

6. Plot the points  $A = (4, 0)$ ,  $B = (4, 5)$ ,  $C = (0, 7)$ , and  $D = (0, 0)$ . Write a series of simultaneous inequalities that describe the region enclosed by the quadrilateral  $ABCD$  formed by joining the four points.

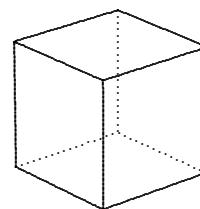

7. The total area of six faces of a cube is 1000 sq cm. What is the length of one edge of the cube? Round your answer to three decimal places.

8. On a recent drive from Exeter to New York City, Taylor maintained an average speed of 50 mph for the first four hours, but could only average 30 mph for the final hour, because of road construction. What was Taylor's average speed for the whole trip? What would the average have been if Taylor had traveled  $x$  hours at 30 mph and  $4x$  hours at 50 mph?

9. Solve each of the following equations. Give decimal answers, accurate to three places.

(a)  $x^2 = 11$       (b)  $5s^2 - 101 = 144$       (c)  $x^2 = 0$       (d)  $30 = 0.4m^2 + 12$

## Mathematics 1

1. Near the surface of the earth, assuming negligible resistance from the air, the height in feet of a falling object is modeled well by the equation  $y = h - 16t^2$ , where  $y$  is the height of the object,  $t$  is the number of seconds the object has been falling, and  $h$  is the height from which the object was dropped.

(a) If an iron ball were dropped from the Washington Monument, which is 555 feet high, how far above the ground would the ball be after 2 seconds of falling? How long would it take for the ball to hit the ground?

(b) Due to air resistance, a falling bag of corn chips will not gain speed as rapidly as a falling iron ball. Cal Elayo, a student of science, found that the descent of a falling bag of chips is modeled well by the equation  $y = h - 2.5t^2$ . In an historic experiment, Cal dropped a bag of chips from a point halfway up the Monument, while a friend simultaneously dropped the iron ball from the top. After how many seconds did the ball overtake the bag of chips?

(c) Graph the equations  $y = 277.5 - 2.5t^2$  and  $y = 555 - 16t^2$  on the same system of axes. Calculate the  $y$ - and  $t$ -intercepts of both curves. What is the meaning of these numbers? Notice that the curves intersect. What is the meaning of the intersection point?

2. You have seen that the graph of any quadratic function is a parabola that is symmetrical with respect to a line called the *axis of symmetry*, and that each such parabola also has a lowest or highest point called the *vertex*. Sketch a graph for each of the following quadratic functions. Identify the coordinates of each vertex and write an equation for each axis of symmetry.

(a)  $y = 3x^2 + 6$       (b)  $y = x^2 + 6x$       (c)  $y = 64 - 4x^2$       (d)  $y = x^2 - 2x - 8$

3. For the point  $(4, 24)$  to be on the graph of  $y = ax^2$ , what should the value of  $a$  be?

4. When asked to solve the equation  $(x - 3)^2 = 11$ , Jess said, "That's easy — just take the square root of both sides." Perhaps Jess also remembered that 11 has two square roots, one positive and the other negative. What are the two values for  $x$ , in exact form? (In this situation, "exact" means no decimals.)

5. (Continuation) When asked to solve the equation  $x^2 - 6x = 2$ , Deniz said, "Hmm . . . not so easy, but I think that adding something to both sides of the equation is the thing to do." This is indeed a good idea, but what number should Deniz add to both sides? How is this equation related to the previous one?

6. Some coffee roasters dealers mix beans with different flavor profiles to customize their product. Selling prices are adjusted appropriately. For example, suppose that a roaster mixed some coffee worth \$6.49 a pound with some coffee worth \$10.89 a pound, thus obtaining 100 pounds of a mixture worth \$9.24 a pound. How many pounds of each type of bean was used for this mixture?

7. Suppose that  $m$  and  $n$  stand for positive numbers, with  $n < m$ . Which of the following expressions has the largest value? Which one has the smallest value?

(a)  $\frac{m+1}{n+1}$       (b)  $\frac{m+1}{n}$       (c)  $\frac{m}{n}$       (d)  $\frac{m}{n+2}$       (e)  $\frac{m}{n+1}$

## Mathematics 1

1. Use your calculator to evaluate the following: (a)  $\frac{\sqrt{50}}{\sqrt{2}}$  (b)  $\frac{\sqrt{28}}{\sqrt{7}}$  (c)  $\frac{\sqrt{294}}{\sqrt{6}}$

Explain why your results make it reasonable to write  $\frac{\sqrt{a}}{\sqrt{b}} = \sqrt{\frac{a}{b}}$ . Check that this rule

- also works for: (d)  $\frac{\sqrt{48}}{\sqrt{6}}$  (e)  $\frac{\sqrt{84}}{\sqrt{12}}$  (f)  $\frac{\sqrt{180}}{\sqrt{15}}$

2. *Rationalizing denominators.* How are the decimal approximations for  $\frac{6}{\sqrt{6}}$  and  $\sqrt{6}$  related? Was this predictable? Verify that the decimal approximations for  $\frac{1}{\sqrt{8}}$  and  $\frac{\sqrt{2}}{4}$  are equal. Was this predictable? What is the effect of multiplying  $\frac{1}{\sqrt{8}}$  and  $\frac{\sqrt{2}}{\sqrt{2}}$ ? To show equivalence of expressions, you might have to transform one radical expression to make it look like another.

3. Without a calculator, decide whether the first expression is equivalent to the second:  
 (a)  $\sqrt{75}$  and  $5\sqrt{3}$  (b)  $\frac{\sqrt{800}}{2}$  and  $10\sqrt{2}$  (c)  $\frac{2}{\sqrt{8}}$  and  $\frac{\sqrt{2}}{2}$  (d)  $\sqrt{\frac{1000}{6}}$  and  $\frac{10\sqrt{15}}{3}$

4. At noon one day, Allie left home to make a long bike ride to the family camp on Mud Lake, a distance of 100 km. Later in the day, the rest of the family packed some things into their van and drove to the lake along Allie's bike route. They overtook Allie after driving for 1.2 hrs, stopped long enough to put Allie and bicycle in the van, and continued to the camp. Refer to the graph as you answer the following questions about the day's events:

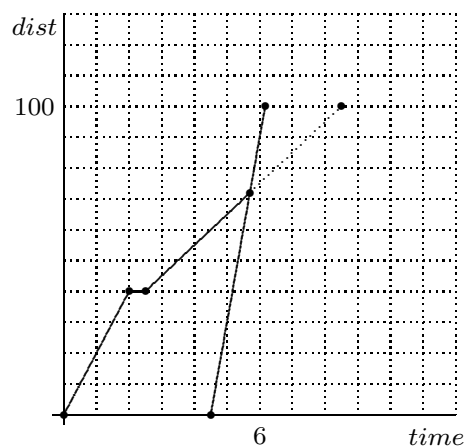

- (a) Allie pedaled at two different rates during the biking part of the trip. What were they?  
 (b) After biking for a while, Allie stopped to take a rest. How far from home was Allie then? How long was the rest?  
 (c) How far from home was Allie when the family caught up?  
 (d) At what time did the family arrive at the camp?  
 (e) At what time would Allie have arrived, if left to bicycle all the way?  
 (f) What distance separated Allie and the rest of the family at 5 pm?

5. Use the distributive property to factor each of the following:

(a)  $x^2 + x^3 + x^4$  (b)  $\pi r^2 + 2\pi r h$  (c)  $25x - 75x^2$  (d)  $px + qx^2$

6. Solving a quadratic equation by rewriting the left side as a perfect-square trinomial is called solving by *completing the square*. Use this method to solve each of the following equations. Leave your answers in exact form.

(a)  $x^2 - 8x = 3$  (b)  $x^2 + 10x = 11$  (c)  $x^2 - 5x - 2 = 0$  (d)  $x^2 + 1.2x = 0.28$

## Mathematics 1

1. The hot-water faucet takes four minutes to fill the tub, and the cold-water faucet takes three minutes for the same job. How long to fill the tub if both faucets are used?

2. Find a quadratic equation for each of the graphs pictured at the right. Each curve has a designated point on it, and the  $y$ -intercepts are all at integer values. Also notice that the  $y$ -axis is the axis of symmetry for all.

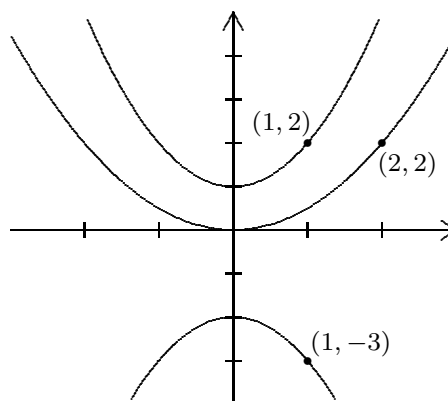

3. The speed of sound in air is 1100 feet per second. The speed of sound in steel is 16500 feet per second. Robin, one ear pressed against the railroad track, hears a sound through the rail six seconds before hearing the same sound through the air. To the nearest foot, how far away is the source of that sound?

4. The point  $(4, 7)$  is on the graph of  $y = x^2 + c$ . What is the value of  $c$ ?

5. In your notebook, use one set of coordinate axes to graph the three curves  $y = x^2 - x$ ,  $y = x^2 + 2x$ , and  $y = x^2 - 4x$ . Make three observations about graphs of the form  $y = x^2 + bx$ , where  $b$  is a nonzero number.

6. Add the first two odd numbers, the first three odd numbers, and the first four odd numbers. Do your answers show a pattern? What is the sum of the first  $n$  odd numbers?

7. (Continuation) Copy the accompanying tables into your notebook and fill in the missing entries. Notice that the third column lists the differences between successive  $y$ -values. Is there a pattern to the column of differences? Do the values in this column describe a linear function? Explain. As a check, create a fourth column that tables the differences of the differences. How does this column help you with your thinking?

$x$	$y$
0	0
1	1
2	4
3	9
4	
5	

<i>diff</i>
1
3

8. (Continuation) Carry out the same calculations, but replace  $y = x^2$  by a quadratic function of your own choosing. Is the new table of differences linear?

9. Write  $(2a)^2$  without parentheses. Is  $(2a)^2$  larger than, smaller than, or the same as  $2a^2$ ? Make reference to the diagram at right in writing your answer. Draw a similar diagram to illustrate the non-equivalence of  $(3a)^2$  and  $3a^2$ .

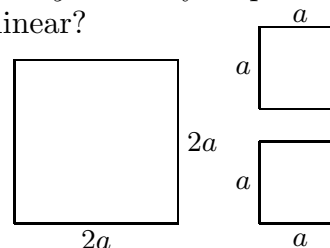

10. Without using a calculator, solve each of the following quadratic equations:

(a)  $(x + 4)^2 = 23$       (b)  $7x^2 - 22x = 0$       (c)  $x^2 - 36x = 205$       (d)  $1415 - 16x^2 = 0$



## Mathematics 1

1. The cost of a ham-and-bean supper at a local church was \$6 for adults and \$4 for children. At the end of the evening, the organizers of the supper found they had taken in a total of \$452 and that 86 persons had attended. How many of these persons were adults?

2. A hose used by the fire department shoots water out in a parabolic arc. Let  $x$  be the horizontal distance from the hose's nozzle, and  $y$  be the corresponding height of the stream of water, both in feet. The quadratic function is  $y = -0.016x^2 + 0.5x + 4.5$ .

(a) What is the significance of the 4.5 that appears in the equation?

(b) Use your calculator to graph this function. Find the stream's greatest height.

(c) What is the horizontal distance from the nozzle to where the stream hits the ground?

(d) Will the stream go over a 6-foot high fence that is located 28 feet from the nozzle? Explain your reasoning.

3. In the diagram, the dimensions of a piece of carpeting have been marked in terms of  $x$ . All lines meet at right angles. Express the area and the perimeter of the carpeting in terms of  $x$ .

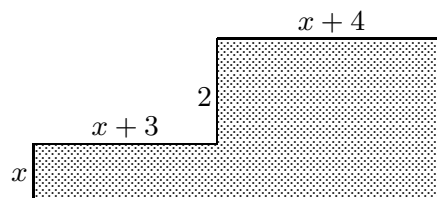

4. Evaluate the expression  $397(2.598) + 845(2.598) - 242(2.598)$  mentally.

5. Kirby is four miles from the train station, from which a train is due to leave in 56 minutes. Kirby is walking along at 3 mph, and could run at 12 mph if it were necessary. If Kirby wants to be on that train, it *will* be necessary to do some running! How many miles of running?

6. The work at right shows the step-by-step process used by a student to solve  $x^2 + 6x - 5 = 0$  by the method of completing the square. Explain why the steps in this process are reversible. Apply this understanding to find a quadratic equation  $ax^2 + bx + c = 0$  whose solutions are  $x = 7 + \sqrt{6}$  and  $x = 7 - \sqrt{6}$ .

$$\begin{aligned} x^2 + 6x - 5 &= 0 \\ x^2 + 6x + 9 &= 5 + 9 \\ (x + 3)^2 &= 14 \\ x + 3 &= \pm\sqrt{14} \\ x &= -3 \pm \sqrt{14} \end{aligned}$$

7. If  $n$  stands for a perfect square, what formula stands for the next largest perfect square?

8. Dale hikes up a mountain trail at 2 mph. Because Dale hikes at 4 mph downhill, the trip down the mountain takes 30 minutes less time than the trip up, even though the downward trail is three miles longer. How many miles did Dale hike in all?

9. Express the areas of the following large rectangles in two ways. First, find the area of each small rectangle and add the expressions. Second, multiply the total length by the total width.

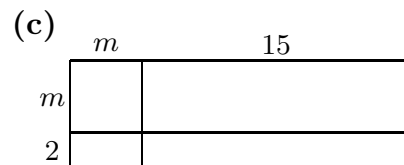
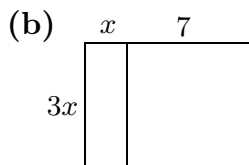
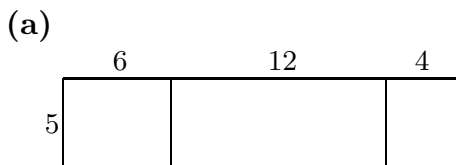

## Mathematics 1

1. The height  $h$  (in feet) above the ground of a baseball depends upon the time  $t$  (in seconds) it has been in flight. Cameron takes a mighty swing and hits a bloop single whose height is described approximately by the equation  $h = 80t - 16t^2$ . Without resorting to graphing on your calculator, answer the following questions:

(a) How long is the ball in the air?

(b) The ball reaches its maximum height after how many seconds of flight?

(c) What is the maximum height?

(d) It takes approximately 0.92 seconds for the ball to reach a height of 60 feet. On its way back down, the ball is again 60 feet above the ground; what is the value of  $t$  when this happens?

2. Apply the zero-product property to solve the following equations:

(a)  $(x - 2)(x + 3) = 0$

(b)  $x(2x + 5) = 0$

(c)  $5(x - 1)(x + 4)(2x - 3) = 0$

3. Solve the following equations, without using a calculator:

(a)  $x^2 - 5x = 0$

(b)  $3x^2 + 6x = 0$

(c)  $ax^2 + bx = 0$

4. During the swimming of a 50-yard sprint in a 25-yard pool, the racers swim away from the starting line and then return to it. Suppose that Alex, who always swims at a steady rate, takes 24 seconds to complete the race. Let  $y$  stand for the distance from Alex to the starting line when the race is  $t$  seconds old. Make a graph of  $y$  versus  $t$ , and write an equation for this graph.

5. In the shot-put competition at the Exeter-Andover track meet, the trajectory of Blair's best put is given by the function  $h = -0.0186x^2 + x + 5.0$ , where  $x$  is the horizontal distance the shot travels, and  $h$  is the corresponding height of the shot above the ground, both measured in feet. Graph the function and calculate how far the shot went. What was the greatest height obtained? In the given context, what is the meaning of the "5.0" in the equation?

6. Sketch the graphs of  $y = x^2 - 12x$ ,  $y = -2x^2 - 14x$ , and  $y = 3x^2 + 18x$ . Write an equation for the symmetry axis of each parabola. Devise a quick way to write an equation for the symmetry axis of any parabola  $y = ax^2 + bx$ . Test your method on the three given examples.

7. Without using a calculator, simplify  $|3 - \sqrt{5}| + 4$  by writing an equivalent expression without absolute-value signs. Do the same for  $|3 - \sqrt{10}| + 4$ . Does your calculator agree?

8. Multiply: (a)  $(3x)(7x)$  (b)  $(3x)(7 + x)$  (c)  $(3 + x)(7 + x)$

## Mathematics 1

1. Given  $P = (1, 4)$ ,  $Q = (4, 5)$ , and  $R = (10, 7)$ , decide whether or not  $PQR$  is a straight line, and give your reasons.

2. All the dimensions of the twelve rectangles in the figure are either  $a$  or  $b$ . Write an expression for the sum of the areas of the twelve pieces. This should help you to show how these twelve pieces can be fit together to form one large rectangle.

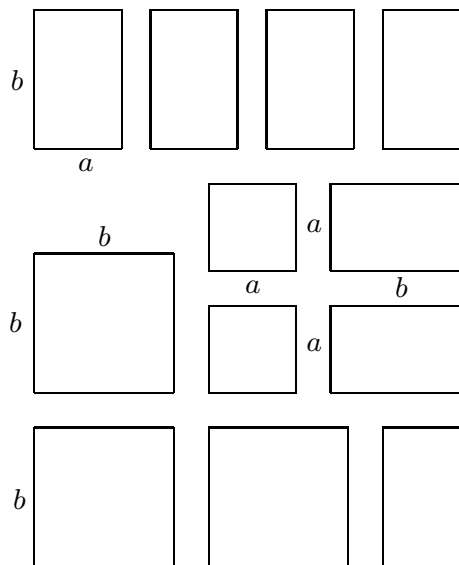

3. Sketch the graphs of  $y = x^2$ ,  $y = (x - 2)^2$ ,  $y = (x + 3)^2$ , and  $y = (x - 5)^2$  on the same set of coordinate axes. Make a general statement as to how the graph of  $y = (x - h)^2$  is related to the graph of  $y = x^2$ .

4. (Continuation) Sketch the graphs  $y = 2(x - 3)^2$ ,  $y = -3(x - 3)^2$ , and  $y = 0.5(x - 3)^2$ . What do these graphs all have in common? How do they differ? What is the equation of a parabola whose vertex is at the point  $(-2, 0)$ , is the same size as the graph  $y = 2(x - 3)^2$ , and opens up?

5. The hands of a clock point in the same direction at noon, and also at midnight. How many times between noon and midnight does this happen?

6. The axis of symmetry of a parabola is the line  $x = 4$ .

(a) Suppose that one  $x$ -intercept is 10; what is the other one?

(b) Suppose the point  $(12, 4)$  is on the graph; what other point also must be on the graph?

7. Given the equation  $s = \pi r + \pi r e$ , solve the formula for: (a)  $e$  (b)  $r$

8. Solve  $x^2 - 2px - 8p^2 = 0$  for  $x$  in terms of  $p$  by completing the square.

9. (Continuation) Show that  $x^2 - 2px - 8p^2$  can be written in factored form.

10. Find the equation of the axis of symmetry for the graph of  $y = 2x^2 - 6x$ . Sketch the graph of this equation in your notebook, including the axis of symmetry. What are the coordinates of the vertex of the graph?

11. (Continuation) Sketch the graph of  $y = 2x^2 - 6x - 3$  along with its axis of symmetry. Find the coordinates of the vertex of this parabola. How do these coordinates compare with the vertex of  $y = 2x^2 - 6x$ ? Find an equation for the graph of a quadratic curve that has the same axis of symmetry as  $y = 2x^2 - 6x$ , but whose vertex is at  $(1.5, -2.5)$ .

## Mathematics 1

1. The table at right displays some values for a quadratic function  $y = ax^2 + bx + c$ .

$x$	0	1	2	3	4
$y$	0	2	6	12	20

(a) Explain how to use the table to show that  $c = 0$ .

(b) A point is on a curve only if the coordinates of the point satisfy the equation of the curve. Substitute the tabled coordinates  $(1, 2)$  into the given equation to obtain a linear equation in which  $a$  and  $b$  are the unknowns. Apply the same reasoning to the point  $(2, 6)$ .

(c) Find values for  $a$  and  $b$  by solving these two linear equations.

(d) Use your values for  $a$  and  $b$  to identify the original quadratic equation. Check your result by substituting the other two tabled points  $(3, 12)$  and  $(4, 20)$  into the equation.

2. Gerry Anium is designing another rectangular garden. It will sit next to a long, straight rock wall, thus leaving only three sides to be fenced. This time, Gerry has bought 150 feet of fencing in one-foot sections. Subdivision into shorter pieces is not possible. The garden is to be rectangular and the fencing (all of which must be used) will go along three of the sides as indicated in the picture.

(a) If each of the two sides attached to the wall were 40 ft long, what would the length of the third side be?

(b) Is it possible for the longest side of the rectangular garden to be 85 feet long? Explain.

(c) Let  $x$  be the length of one of the sides attached to the wall. Find the lengths of the other two sides, in terms of  $x$ . Is the variable  $x$  continuous or discrete?

(d) Express the area of the garden as a function of  $x$ , and graph this function. For what values of  $x$  does this graph have meaning?

(e) Graph the line  $y = 2752$ . Find the coordinates of the points of intersection with this line and your graph. Explain what the coordinates mean with relation to the garden.

(f) Gerry would like to enclose the largest possible area possible with this fencing. What dimensions for the garden accomplish this? What is the largest possible area?

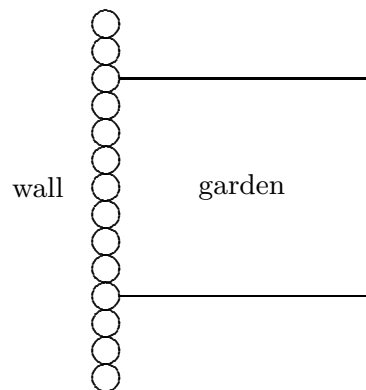

3. Lee finds the identity  $(a + b)^2 = a^2 + 2ab + b^2$  useful for doing mental arithmetic. For example, just ask Lee for the value of  $75^2$ , and you will get the answer 5625 almost immediately — with no calculator assistance. The trick is to use algebra by letting  $10k + 5$  represent a typical integer that ends with 5. Show that the square of this number is represented by  $100k(k + 1) + 25$ . This should enable you to explain how Lee is able to calculate  $75^2 = 5625$  so quickly. Try the trick yourself: Evaluate  $35^2$ ,  $95^2$ , and  $205^2$  without using calculator, paper, or pencil.

4. Sketch the graphs of  $y = (x - 4)^2$  and  $y = 9$  on your calculator screen. What are the coordinates of the point(s) of intersection? Now solve the equation  $(x - 4)^2 = 9$ . Describe the connection between the points of intersection on the graph and the solution(s) to the equation.

## Mathematics 1

1. The graph of  $y = x^2 - 400$  is shown at right. Notice that no coordinates appear in the diagram. There are tick marks on the axes, however, which enable you, without using your graphing calculator, to figure out the actual window that was used for this graph. Find the high and low values for both the  $x$ -axis and the  $y$ -axis. After you get your answer, check it on your calculator. To arrive at your answer, did you actually need to have tick marks on both axes?

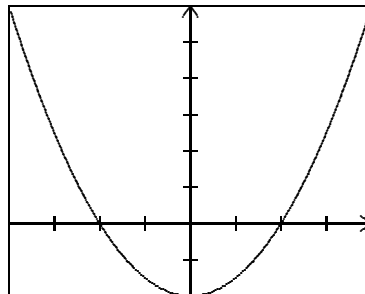

2. Sketch the graph of  $y = x^2 + 3$  and  $y = |x| + 3$  on the same axis in your notebook. List three ways that the two graphs are alike and three ways in which they differ. Be sure your graph is large enough to clearly show these differences. On another axis, sketch the graph of  $y = 2(x - 3)^2$  and  $y = 2|x - 3|$ . Also be prepared to explain how these two graphs compare.

3. As shown below, the expression  $5(x + 2)(x + 3)$  can be pictured as five rectangles, each one with dimensions  $(x + 2)$  by  $(x + 3)$ .

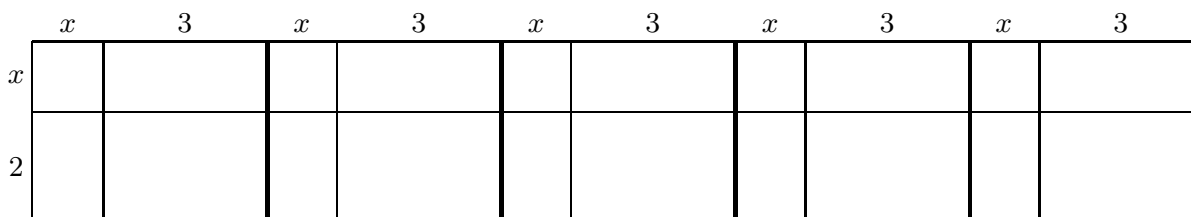

- (a) Write out the product  $5(x + 2)(x + 3)$ , and show that it also corresponds to the diagram.  
 (b) Explain why  $5(x + 2)(x + 3)$  is equivalent to  $(x + 2)(5x + 15)$ , using algebraic code as well as a labeled diagram to support your answer.

4. When asked to find the equation of the parabola pictured at right, Ryan took one look at the  $x$ -intercepts and knew that the answer had to look like  $y = ax(x - 3)$ , for some value of  $a$ . Justify Ryan's reasoning, then finish the problem by finding the correct value of  $a$ .

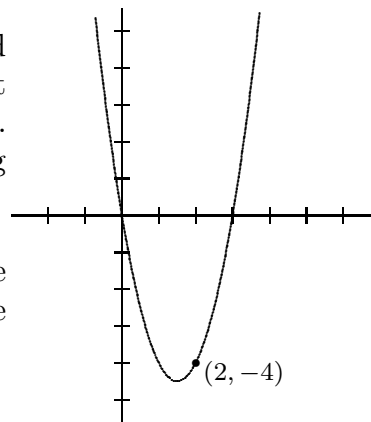

5. (Continuation) Find an equation for the parabola whose symmetry axis is parallel to the  $y$ -axis, whose  $x$ -intercepts are  $-2$  and  $3$ , and whose  $y$ -intercept is  $4$ .

6. There are many quadratic functions whose graphs intersect the  $x$ -axis at  $(0, 0)$  and  $(6, 0)$ . Sketch graphs for a few of them, including the one that goes through  $(3, 9)$ . Other than their axis of symmetry, what do all these graphs have in common? How do the graphs differ?

## Mathematics 1

1. In solving an equation such as  $2x^2 - 5x = 3$  by completing the square, it is customary to first divide each term by 2 so that the coefficient of  $x^2$  is 1. This transforms the equation into  $x^2 - \frac{5}{2}x = \frac{3}{2}$ . Now continue to solve by the completing the square method, remembering to take half of  $\frac{5}{2}$ , square it and add it to *both* sides of the equation. Complete the solution.

2. *Completing the square.* Confirm that the equation  $ax^2 + bx + c = 0$  can be converted into the form  $x^2 + \frac{b}{a}x = -\frac{c}{a}$ . Describe the steps. To achieve the goal suggested by the title, what should now be added to both sides of this equation?

3. (Continuation) The left side of the equation  $x^2 + \frac{b}{a}x + \frac{b^2}{4a^2} = \frac{b^2}{4a^2} - \frac{c}{a}$  can be factored as a perfect square trinomial. Show how. The right side of the equation can be combined over a common denominator. Show how. Finish the solution of the general quadratic equation by taking the square root of both sides of your most recent equation. The answer is called *the quadratic formula*. You may be able to check your formula using your calculator. Apply your formula: Solve  $x^2 + 2x - 3 = 0$  by letting  $a = 1$ ,  $b = 2$ , and  $c = -3$ .

4. As long as the coefficients  $a$  and  $b$  are nonzero, the parabolic graph  $y = ax^2 + bx$  has two  $x$ -intercepts. What are they? Use them to find the axis of symmetry for this parabola. Explain why the axis of symmetry for  $y = 2x^2 - 5x - 12$  is the same as the axis of symmetry for  $y = 2x^2 - 5x$ . In general, what is the symmetry axis for  $y = ax^2 + bx + c$ ? Does your description make sense for  $y = 2x^2 - 5x + 7$ , even though the curve has no  $x$ -intercepts?

5. (Continuation). If you know the axis of symmetry for a quadratic function, how do you find the coordinates of the vertex? Try your method on each of the following, by first finding the symmetry axis, then the coordinates of the vertex.

(a)  $y = x^2 + 2x - 3$       (b)  $y = 3x^2 + 4x + 1$

6. Graph the equations  $y = (x-5)^2$ ,  $y = (x-5)^2 - 4$ , and  $y = (x-5)^2 + 2$ . Write the coordinates of the vertex for each curve. Describe how to transform the first parabola to obtain the other two. A fourth parabola is created by shifting the first parabola so that its vertex is  $(5, -7)$ . Write an equation for the fourth parabola.

7. Find an equation for each of the functions graphed at right. Each one is either an absolute-value function or a quadratic function.

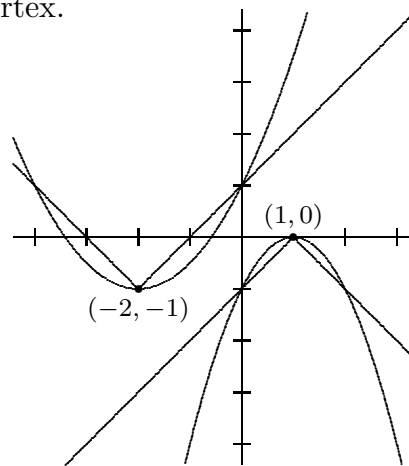

## Mathematics 1

1. The driver of a red sports car, moving at  $r$  feet per second, sees a pedestrian step out into the road. Let  $d$  be the number of feet that the car travels, from the moment when the driver *sees* the danger until the car has been brought to a complete stop. The equation  $d = 0.75r + 0.03r^2$  models the typical panic-stop relation between stopping distance and speed.

(a) Moving the foot from the accelerator pedal to the brake pedal takes a typical driver three fourths of a second. What does the term  $0.75r$  represent in the stopping-distance equation? The term  $0.03r^2$  comes from physics; what must it represent?

(b) How much distance is needed to bring a car from 30 miles per hour (which is equivalent to 44 feet per second) to a complete stop?

(c) How much distance is needed to bring a car from 60 miles per hour to a complete stop?

(d) Is it true that doubling the speed of the car doubles the distance needed to stop it?

2. (Continuation) At the scene of a crash, an officer observed that a car had hit a wall 150 feet after the brakes were applied. The driver insisted that the speed limit of 45 mph had not been broken. What do you think of this evidence?

3. Consider the triangular arrangements of hearts shown below:



(a) In your notebook, continue the pattern by drawing the next triangular array.

(b) Let  $x$  equal the number of hearts along one edge of a triangle, and let  $y$  equal the corresponding number of hearts in the whole triangle. Make a table of values that illustrates the relationship between  $x$  and  $y$  for  $1 \leq x \leq 6$ . What value of  $y$  should be associated with  $x = 0$ ?

(c) Is the relationship between  $x$  and  $y$  linear? Explain. Is the relationship quadratic? Explain.

(d) Is  $y$  a function of  $x$ ? Is  $x$  a function of  $y$ ? Explain.

(e) The numbers 1, 3, 6, 10, ... are called *triangular numbers*. Why? Find an equation for the triangular number relationship. Check it by replacing  $x$  with 6. Do you get the same number as there are hearts in the 6<sup>th</sup> triangle?

4. If a hen and a half can lay an egg and a half in a day and a half, then how much time is needed for three hens to lay three eggs?

5. The equation  $y = 50x - 0.5x^2$  describes the trajectory of a toy rocket, in which  $x$  is the number of feet the rocket moves horizontally from the launch, and  $y$  is the corresponding number of feet from the rocket to the ground. The rocket has a sensor that causes a parachute to be deployed when activated by a laser beam.

(a) If the laser is aimed along the line  $y = 20x$ , at what altitude will the parachute open?

(b) At what slope could the laser be aimed to make the parachute open at 1050 feet?

## Mathematics 1

1. Perform the indicated operations and combine like terms where possible:

(a)  $(x + 6)(x - 7)$                       (b)  $(x - 5)^2$                       (c)  $(x + 9)(x - 9)$

2. Sketch the graphs of  $y = (x - 4)^2$  and  $y = (4 - x)^2$ . What do you notice about the graphs? Explain why this is true.

3. Jess bought a can of paint, whose label stated that the contents of the can were sufficient to cover 150 square feet. To the nearest inch, what are the dimensions of the largest square that Jess could cover using this paint?

4. The PEA Ski Club is planning a ski trip for the upcoming long weekend. They have 40 skiers signed up to go, and the ski resort is charging \$120 for each person.

(a) Calculate how much money (revenue) the resort expects to take in.

(b) The resort manager offers to reduce the group rate of \$120 per person by \$2 for each additional registrant, up to a maximum number  $m$ . For example, if five more skiers were to sign up, all 45 would pay \$110 each, producing revenue \$4950 for the resort. Fill in the rest of the table at right, and you will discover the manager's value of  $m$ .

<i>extras</i>	<i>persons</i>	<i>cost/person</i>	<i>revenue</i>
0			
1			
2			
3			
4			
5	45	110	4950
6			
7			
8			
9			
10			
11			
12			

(c) Let  $x$  be the number of new registrants. In terms of  $x$ , write expressions for the total number of persons going, the cost to each, and the resulting revenue for the resort.

(d) Plot your revenue values versus  $x$ , for the relevant values of  $x$ . Because this is a discrete problem, it does not make sense to connect the dots.

(e) For the resort to take in at least \$4900, how many PEA skiers must go on trip?

5. The diagram at the right suggests an easy way of making a box with no top. Start with a square piece of cardboard, cut squares of equal sides from the four corners, and then fold up the sides. Here is the problem: To produce a box that is 8 cm deep and whose capacity is exactly one liter (1000 cc). How large a square must you start with (to the nearest mm)?

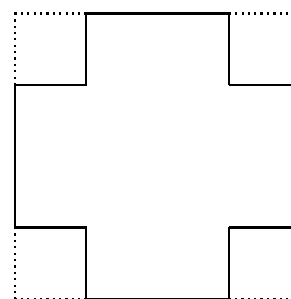

6. The area of a rectangle is 12 square feet, and each of its dimensions is an integral number of feet. What are the dimensions of all the possible rectangles that could have this area? What are all the integral factors of 12?



## Mathematics 1

1. Use the distributive property to multiply  $(x+p)(x+q)$ . The result of this multiplication can be expressed in the form  $x^2 + \nabla x + \Delta$ ; what do  $\nabla$  and  $\Delta$  stand for?
2. (Continuation) When attempting to factor  $x^2 + 5x + 4$  into a product of two binomials of the form  $(x+p)(x+q)$ , Dylan set up the identity  $x^2 + 5x + 4 = (x + \quad)(x + \quad)$ . Using a trial-and-error process, try to figure out what numbers go in the blank spaces. What is the connection between the numbers in the blank spaces and the coefficients 5 and 4 in the quadratic expression being factored?
3. (Continuation) Use the same trial-and-error process to express each of the following trinomials as a product of two binomials:  
(a)  $x^2 + 6x + 5$       (b)  $x^2 - 7x + 12$       (c)  $x^2 + 3x - 4$       (d)  $x^2 - x - 6$
4. Solve the following quadratic equations:  
(a)  $x^2 + 6x + 5 = 0$     (b)  $x^2 - 7x + 12 = 0$     (c)  $x^2 + 3x - 4 = 0$     (d)  $x^2 - x - 6 = 0$
5. The three functions  $y = 2(x - 4) - 1$ ,  $y = 2|x - 4| - 1$ , and  $y = 2(x - 4)^2 - 1$  look somewhat similar. Predict what the graph of each will look like, and then sketch them in your notebook (without using a calculator) by just plotting a few key points. In each case think about how the form of the equation can help provide information.
6. Without using a calculator, make a sketch of the parabola  $y = (x - 50)^2 - 100$ , by finding the  $x$ -intercepts, the  $y$ -intercept, and the coordinates of the vertex. Label all four points with their coordinates on your graph.
7. When taking an algebra quiz, Dale was asked to factor the trinomial  $x^2 + 3x + 4$ . Dale responded that this particular trinomial was not factorable. Decide whether Dale was correct, and justify your response.
8. The graph of a quadratic function intersects the  $x$ -axis at 0 and at 8. Draw two parabolas that fit this description and find equations for them. How many examples are possible?
9. Find an equation for the parabola whose  $x$ -intercepts are 0 and 8, whose axis of symmetry is parallel to the  $y$ -axis, and whose vertex is at  
(a)  $(4, -16)$       (b)  $(4, -8)$       (c)  $(4, -4)$       (d)  $(4, 16)$
10. Find the value for  $c$  that forces the graph of  $3x + 4y = c$  to go through  $(2, -3)$ .
11. Solve  $x^2 + bx + c = 0$  by the method of completing the square. Apply your answer to the example  $x^2 + 5x + 6 = 0$  by setting  $b = 5$  and  $c = 6$ .

## Mathematics 1

1. Pat and Kim own a small, pleasant house that is rectangular in shape, 50 feet by 30 feet. They want to add on a family room that will be square, and then fill in the space adjoining the new room with a deck. A plan of the setup is at the right. They have not decided how large a family room to build, but they do have 400 square feet of decking. If they use it all, and keep to the plan, how large will the family room be? Is there more than one solution to this problem?

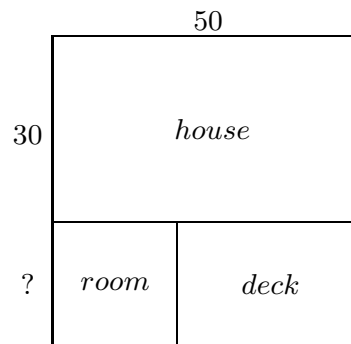

2. Write in as compact form as possible:

(a)  $x^4 \cdot \frac{1}{x^3}$       (b)  $\left(\frac{2}{x^3}\right)^4$       (c)  $(2x + x + 2x)^3$       (d)  $\frac{x^6}{x^2}$

3. For each of the following, first write down the factors of the given expression. Then graph the function and record the  $x$ -intercepts.

- (a) Factor  $x^2 - 4x - 5$  and then graph  $y = x^2 - 4x - 5$ .  
 (b) Factor  $x^2 + 12x + 35$  and then graph  $y = x^2 + 12x + 35$ .  
 (c) Factor  $x^2 - 3x + 2$  and then graph  $y = x^2 - 3x + 2$ .

What is the connection between factoring a polynomial and finding the  $x$ -intercepts of its graph? Explain how the graph of a polynomial can help in the search for factors.

4. (Continuation) Find the solutions to the equations

(a)  $x^2 - 4x - 5 = 0$       (b)  $x^2 + 12x + 35 = 0$       (c)  $x^2 - 3x + 2 = 0$

Explain the reasoning used to solve a polynomial equation that is in factored form.

5. By using square roots, express the solutions to  $(x - 5)^2 - 7 = 0$  exactly (no decimals).

6. By rearranging the pieces of the puzzle shown at right, show that  $a^2 - b^2$  is equivalent to  $(a + b)(a - b)$ .

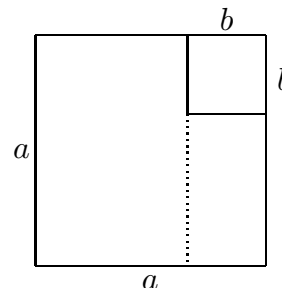

7. Expand the following products:

(a)  $(x - 4)(x + 4)$     (b)  $(x + 7)(x - 7)$     (c)  $(3x - 2)(3x + 2)$

Use the pattern to predict the factors of  $x^2 - 64$  and  $4x^2 - 25$ .

Explain why this pattern is called *the difference of two squares*.

8. Find the  $x$ -intercepts of the following graphs, without expanding the squared binomial that appears in each:

(a)  $y = (x - 4)^2 - 9$       (b)  $y = -2(x + 3)^2 + 8$

Check your work by sketching each parabola, incorporating the vertex and  $x$ -intercepts.

## Mathematics 1

1. The *degree* of a monomial counts how many variable factors would appear if it were written without using exponents. For example, the degree of  $6ab$  is 2, and the degree of  $25x^3$  is 3, since  $25x^3 = 25xxx$ . The degree of a polynomial is the largest degree found among its monomial terms. Find the degree of the following polynomials:

(a)  $x^2 - 6x$       (b)  $5x^3 - 6x^2$       (c)  $x^4 + 4x^3y + 6x^2y^2 + 4xy^3 + y^4$       (d)  $4\pi r^2h$

2. Find at least three integers (positive or negative) that, when put in the blank space, make the expression  $x^2 + \underline{\hspace{1cm}}x - 36$  a factorable trinomial. Are there other examples? How many?

3. (Continuation) Find at least three integers that, when put in the blank space, make the expression  $x^2 + 4x - \underline{\hspace{1cm}}$  a factorable trinomial. Are there other examples? How many? What do all these integers have in common?

4. Combine into one fraction:

(a)  $\frac{1}{3} + \frac{1}{7}$                                       (b)  $\frac{1}{15} + \frac{1}{19}$                                       (c)  $\frac{1}{x-2} + \frac{1}{x+2}$

Evaluate your answer to part (c) with  $x = 5$  and  $x = 17$ . How do these answers compare to your answers in parts (a) and (b)?

5. Plot a point near the upper right corner of a sheet of graph paper. Move your pencil 15 graph-paper units (squares) to the left and 20 units down, then plot another point. Use your ruler to measure the distance between the points. Because the squares on your graph paper are probably larger or smaller than the squares on your classmates' graph paper, it would not be meaningful to compare ruler measurements with anyone else in class. You should therefore finish by converting your measurement to graph-paper units.

6. (Continuation) Square your answer (in graph-paper units), and compare the result with the calculation  $15^2 + 20^2$ .

7. (Continuation) Repeat the entire process, starting with a point near the upper left corner, and use the instructions "20 squares to the right and 21 squares down." You should find that the numbers in this problem again fit the equation  $a^2 + b^2 = c^2$ . These are instances of the *Pythagorean Theorem*, which is a statement about right-angled triangles. Write a clear statement of this useful result. You will need to refer to the longest side of a right triangle, which is called the *hypotenuse*.

8. A cylindrical container is filled to a depth of  $d$  cm by pouring in  $V$  cc of liquid. Draw a plausible graph of  $d$  versus  $V$ .

9. The product of two polynomials is also a polynomial. Explain. When a polynomial of degree 3 is multiplied by a polynomial of degree 2, what is the degree of the result?

## Mathematics 1

1. When asked to find the equation of the parabola pictured at right, Ryan reasoned that the correct answer had to look like  $y = a(x - 2)^2 + 3$ , for some value of  $a$ . Justify Ryan's reasoning, then finish the problem by finding the correct value of  $a$ .

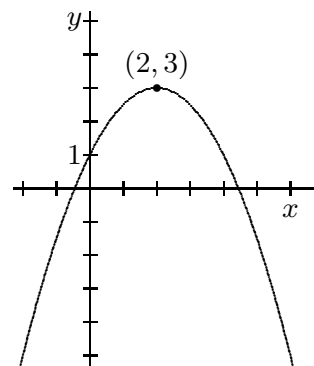

2. (Continuation) Find an equation for the parabola whose symmetry axis is parallel to the  $y$ -axis, whose vertex is  $(-1, 4)$ , and whose graph contains the point  $(1, 3)$ .

3. Starting at school, you and a friend ride your bikes in different directions — you ride 4 blocks north and your friend rides 3 blocks west. At the end of this adventure, how far apart are you and your friend?

4. From the library, you ride your bike east at a rate of 10 mph for half an hour while your friend rides south at a rate of 15 mph for 20 minutes. How far apart are you? How is this problem similar to the preceding problem? How do the problems differ?

5. A small calculator company is doing a study to determine how to price one of its new products. The theory is that the income  $r$  from a product is a function of the market price  $p$ , and one of the managers has proposed that the quadratic model  $r = p \cdot (3000 - 10p)$  provides a realistic approximation to this function.

(a) What was the manager's reasoning in devising this formula?

(b) What is the significance of the value  $p = 300$  in this investigation?

(c) Assume that this model is valid, and figure out the best price to charge for the calculator. How much income for the company will the sales of this calculator provide?

(d) If the management is going to be satisfied as long as the income from the new calculator is at least \$190000, what range of prices  $p$  will be acceptable?

6. Imagine a circle of rope, which has twelve evenly spaced knots tied in it. Suppose that this rope has been pulled into a taut, triangular shape, with stakes anchoring the rope at knots numbered 1, 4, and 8. Make a conjecture about the angles of the triangle.

7. Combine over a common denominator:      (a)  $\frac{1}{x-3} + \frac{2}{x}$       (b)  $\frac{1}{x-3} + \frac{2}{x+3}$

8. The diagram at right shows the flag of Finland, which consists of a blue cross, whose width is a uniform 9 inches, against a solid white background. The flag measures 2 feet 9 inches by 4 feet 6 inches. The blue cross occupies what fractional part of the whole flag?

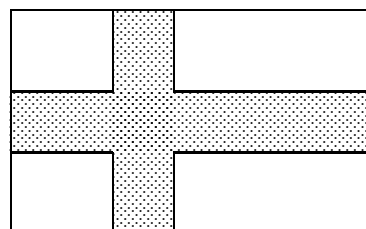

## Mathematics 1

1. In baseball, the infield is a square that is 90 feet on a side, with bases located at three of the corners, and home plate at the fourth. If the catcher at home plate can throw a baseball at 70 mph, how many seconds does it take for the thrown ball to travel from home plate to 2<sup>nd</sup> base?

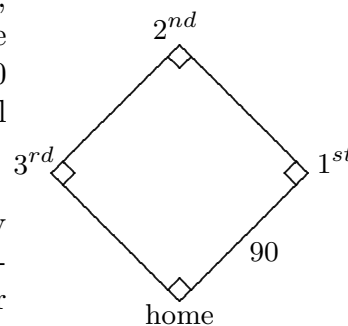

2. Graph the equation  $y = (x - 5)^2 - 7$  without a calculator by plotting its vertex and its  $x$ -intercepts (just estimate their positions between two consecutive integers). Then use your calculator to draw the parabola. Repeat the process on  $y = -2(x+6)^2 + 10$ .

3. At most how many solutions can a quadratic equation have? Give an example of a quadratic equation that has two solutions. Give an example of a quadratic equation that has only *one* solution. Give an example of a quadratic equation that has *no* solutions.

4. While flying a kite at the beach, you notice that you are 100 yards from the kite's shadow, which is directly beneath the kite. You also know that you have let out 150 yards of string. How high is the kite?

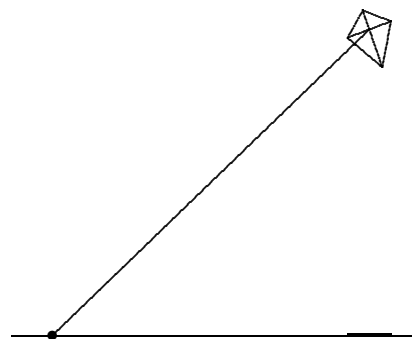

5. Starting from home, Jamie haphazardly walks 2 blocks north, 3 blocks east, 1 block north, 3 blocks east, 1 block north, 5 blocks east, and 1 block north. How far is Jamie from home if each block is 150 meters long?

6. The sides of Fran's square are 5 cm longer than the sides of Tate's square. Fran's square has 225 sq cm more area. What is the area of Tate's square?

7. In the figure at right,  $BAD$  is a right angle, and  $C$  is the midpoint of segment  $AB$ . Given the dimensions marked in the figure, find the length of  $CD$ .

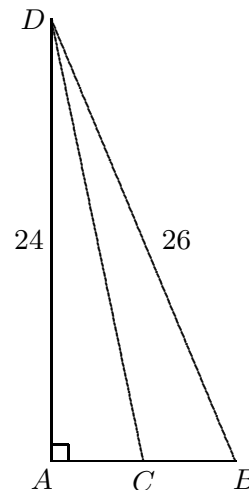

8. Graph the three points  $(-2, 1)$ ,  $(3, 1)$ , and  $(0, 7)$ . There is a quadratic function whose graph passes through these three points. Sketch the graph. Find its equation in two ways: First, begin with the equation  $y = ax^2 + bx + c$  and use the three points to find the values of  $a$ ,  $b$ , and  $c$ . (One of these values is essentially given to you.) Second, begin with the equation  $y = a(x - h)^2 + k$  and use the three points to determine  $a$ ,  $h$ , and  $k$ . (One of these values is almost given to you.) Your two equations do not look alike, but they should be equivalent. Check that they are.

9. Is it possible for a rectangle to have a perimeter of 100 feet *and* an area of 100 square feet? Justify your response.

## Mathematics 1

1. Solve each of the following by the method of completing the square:

(a)  $3x^2 - 6x = 1$

(b)  $2x^2 + 8x - 17 = 0$

2. Find the  $x$ -intercepts of  $y = a(x - 6a)^2 - 4a^3$  in terms of  $a$ .

3. The *period* of a pendulum is the time  $T$  it takes for it to swing back and forth once. This time (measured in seconds) can be expressed as a function of the pendulum length  $L$ , measured in feet, by the physics formula  $T = \frac{1}{4}\pi\sqrt{2L}$ .

(a) To the nearest tenth of a second, what is the period for a 2-foot pendulum?

(b) To the nearest inch, how long is a pendulum whose period is 2.26 seconds?

4. A football field is a rectangle, 300 feet long (from goal to goal) and 160 feet wide (from sideline to sideline). To the nearest foot, how far is it from one corner of the field (on one of the goal lines) to the furthest corner of the field (on the other goal line)?

5. Sam breeds horses, and is planning to construct a rectangular corral next to the barn, using a side of the barn as one side of the corral. Sam has 240 feet of fencing available, and has to decide how much of it to allocate to the width of the corral.

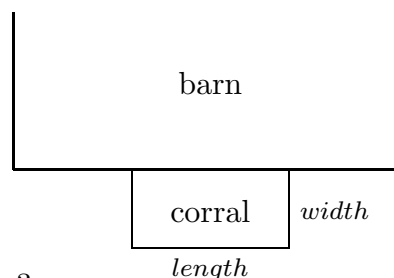

(a) Suppose the width is 50 feet. What is the length? How much area would this corral enclose?

(b) Suppose the width is 80 feet. What is the enclosed area?

(c) Suppose the width is  $x$  feet. Express the length and the enclosed area in terms of  $x$ .

6. (Continuation) Let  $y$  stand for the area of the corral that corresponds to width  $x$ . Notice that  $y$  is a quadratic function of  $x$ . Sketch a graph of  $y$  versus  $x$ . For what values of  $x$  does this graph make sense? For what value of  $x$  does  $y$  attain its largest value? What are the dimensions of the corresponding corral?

7. In each of the following, supply the missing factor:

(a)  $2x^2 + 5x - 12 = (2x - 3)(\quad)$

(b)  $3x^2 - 2x - 1 = (3x + 1)(\quad)$

(c)  $4y^2 - 8y + 3 = (2y - 1)(\quad)$

(d)  $6t^2 - 7t - 3 = (3t + 1)(\quad)$

8. Which of the following calculator screens could be displaying the graph of  $y = x^2 - 2x$ ?

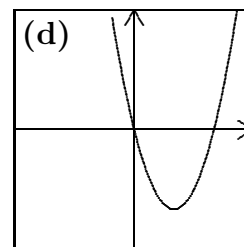
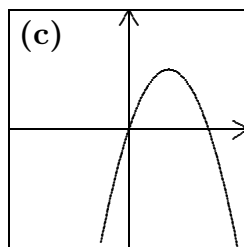
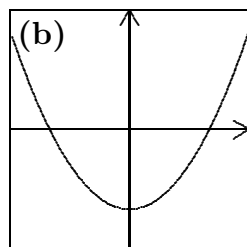
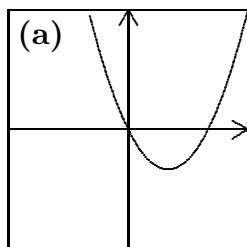

## Mathematics 1

1. Refer to the diagram at right and find the value of  $x$  for which triangle  $ABC$  has a right angle at  $C$ .

2. The final digit of  $3^6$  is 9. What is the final digit of  $3^{2001}$ ?

3. The mathematician Augustus de Morgan enjoyed telling his friends that he was  $x$  years old in the year  $x^2$ . Figure out the year of de Morgan's birth, given that he died in 1871.

4. (Continuation) Are there persons alive today who can truthfully make the same statement that de Morgan did?

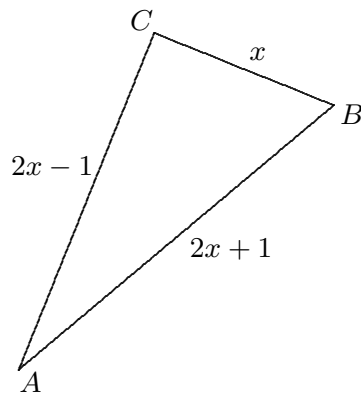

5. Evaluate  $\sqrt{x^2 + y^2}$  using  $x = 24$  and  $y = 10$ . Is  $\sqrt{x^2 + y^2}$  equivalent to  $x + y$ ? Does the square-root operation “distribute” over addition?

6. Evaluate  $\sqrt{(x + y)^2}$  using  $x = 24$  and  $y = 10$ . Is  $\sqrt{(x + y)^2}$  equivalent to  $x + y$ ? Explain.

7. Evaluate  $\sqrt{(x + y)^2}$  using  $x = -24$  and  $y = 10$ . Is  $\sqrt{(x + y)^2}$  equivalent to  $x + y$ ? Explain.

8. Graph the equation  $y = -2x^2 + 5x + 33$ . For what values of  $x$

(a) is  $y = 0$ ?                      (b) is  $y = 21$ ?                      (c) is  $y \geq 0$ ?

9. Factor:

(a)  $x^2 - 81$                       (b)  $4x^2 - 81$                       (c)  $81 - x^2$                       (d)  $0.04x^2 - 81$

10. Sketch the graphs of  $y = 3\sqrt{x}$  and  $y = x + 2$ , and then find their points of intersection. Now solve the equation  $3\sqrt{x} = x + 2$  by first squaring both sides of the equation. Do your answers agree with those obtained from the graph?

11. The expression  $4x + 3x$  can be combined into one term, but  $4x + 3y$  cannot. Explain. Can  $4\sqrt{5} + 3\sqrt{5}$  be combined into one term? Can  $\sqrt{2} + \sqrt{2}$  be combined into one term? Can  $\sqrt{2} + \sqrt{3}$  be combined into one term? At first glance, it may seem that  $\sqrt{2} + \sqrt{8}$  cannot be combined into one term. Take a close look at  $\sqrt{8}$  and show that  $\sqrt{2} + \sqrt{8}$  can in fact be combined.

12. I have been observing the motion of a really tiny red bug on my graph paper. When I started watching, the bug was at the point  $(3, 4)$ . Ten seconds later it was at  $(5, 5)$ . Another ten seconds later it was at  $(7, 6)$ . After another ten seconds it was at  $(9, 7)$ .

(a) Draw a picture that illustrates what is happening.

(b) Write a description of any pattern that you notice. What assumptions are you making?

(c) Where was the bug 25 seconds after I started watching it?

(d) Where was the bug 26 seconds after I started watching it?

## Mathematics 1

1. I am thinking of a right triangle, whose sides can be represented by  $x - 5$ ,  $2x$ , and  $2x + 1$ . Find the lengths of the three sides.
2. Last year, I spent \$72 to buy a lot of ping-pong balls to use in geometry class. This year, the price of a ping-pong ball is 6 cents higher, and \$72 buys 60 fewer balls. Figure out how many ping-pong balls I bought last year.
3. Because  $\sqrt{8}$  can be rewritten as  $2\sqrt{2}$ , the expression  $\sqrt{8} + 5\sqrt{2}$  can be combined into a single term  $7\sqrt{2}$ . Combine each of the following into one term, without using a calculator:  
(a)  $\sqrt{12} + \sqrt{27}$       (b)  $\sqrt{63} - \sqrt{28}$       (c)  $\sqrt{6} + \sqrt{54} + \sqrt{150}$       (d)  $2\sqrt{20} - 3\sqrt{45}$
4. In performing a controlled experiment with fruit flies, Wes finds that the population of male fruit flies is modeled by the equation  $m = 2.2t^2 - 1.6t + 8$ , while the female population is modeled by the equation  $f = 1.6t^2 + 2.8t + 9$ , where  $t$  is the number of days since the beginning of the first day (thus  $t = 2$  is the end of the second day). Assume that all flies live for the duration of the experiment.  
(a) At the *beginning* of the first day, there are how many more female flies than male flies?  
(b) Do male flies ever outnumber female flies? If so, when does that occur?  
(c) Find an equation that models the total number  $n$  of flies that exist at time  $t$ . How many are present at the end of the tenth day? At what time are there 1000 fruit flies in the population?
5. Solve each of the following for  $x$ . Leave your answers in exact form.  
(a)  $x\sqrt{2} = \sqrt{18}$       (b)  $x\sqrt{6} = -\sqrt{30}$       (c)  $\sqrt{2x} = 5$       (d)  $2\sqrt{5x} = \sqrt{30}$
6. Show by finding examples that it is hardly ever true that  $\sqrt{a+b}$  is the same as  $\sqrt{a} + \sqrt{b}$ .
7. Expand each of the following expressions and collect like terms:  
(a)  $(x+2)^3$       (b)  $(x+3)(x^2 - 3x + 9)$       (c)  $1 - (x+1)^2$       (d)  $(2x+1)^2 - 2(x+1)^2$
8. Given that  $\sqrt{72} + \sqrt{50} - \sqrt{18} = \sqrt{h}$ , find  $h$  without using a calculator.
9. My car averages 35 miles to a gallon of gas. When the price of gasoline was \$3.09 per gallon, what was the cost per mile for gasoline for this car? What was the average distance I could travel per dollar?
10. What is the exact value of the expression  $x^2 - 5$  when  $x = 2 + \sqrt{5}$ ?
11. From its initial position at  $(1, 6)$ , an object moves linearly with constant speed. It reaches  $(7, 10)$  after two seconds and  $(13, 14)$  after four seconds.  
(a) Predict the position of the object after six seconds; after nine seconds; after  $t$  seconds.  
(b) Will there be a time when the object is the same distance from the  $x$ -axis as it is from the  $y$ -axis? If so, when, and where is the object?



## Mathematics 1

1. By averaging 60 miles an hour, Allie made a 240-mile trip in just 4 hours. If Allie's average speed had been only 40 miles per hour, how many hours would the same trip have taken? Record your answer in the given table, then complete the table, knowing that the whole trip was 240 miles.

<i>mph</i>	<i>hrs</i>
10	24
20	12
	8
40	
	4.8
60	4

- (a) Multiply 10 by 24, 20 by 12, etc. What do you notice?  
 (b) Sketch the graph of  $y = \frac{240}{x}$ , where  $x$  is speed and  $y$  is time.  
 (c) What are meaningful values for the speed? Is there a largest one? Is there a smallest?  
 (d) Is  $y$  a linear function of  $x$ ? Is  $y$  a quadratic function of  $x$ ? Explain.

2. *Eureka!* A museum acquires an ancient crown that was supposed to be pure gold. Because of suspicions that the crown also contains silver, the crown is measured. Its weight is 42 ounces and its volume is 4 cubic inches. Given that gold weighs 11 ounces per cubic inch and silver weighs 6 ounces per cubic inch, and assuming that the crown really *is* an alloy of silver and gold, figure out how many ounces of silver are mixed with the gold.

3. A sign going down a hill on Route 89 says "8% grade. Trucks use lower gear." The hill is a quarter of a mile long. How many vertical feet will a truck descend while going from the top of the hill to the bottom?

4. Find the  $x$ -intercepts in exact form of each of the following graphs:

(a)  $y = (x - 6)^2 - 10$     (b)  $y = 3(x - 7)^2 - 9$     (c)  $y = 120 - 3x^2$     (d)  $y = 4.2 - 0.7x^2$

5. In each of the following, collect like terms where possible:

(a)  $7\sqrt{6} + 3\sqrt{6}$     (b)  $13\sqrt{3} - 5\sqrt{3}$     (c)  $\sqrt{32} - \sqrt{72}$     (d)  $\sqrt{243} + \sqrt{48} - \sqrt{108}$

6. Given that  $\sqrt{k} = \sqrt{2} + \sqrt{2} + \sqrt{2} + \sqrt{2} + \sqrt{2}$ , find the value of  $k$  without using a calculator.

7. Casey loves movies, but has just heard that the IOKA is raising the price of a movie to \$7. Casey decides to buy a DVD player for \$171 and rent movies from Netflix for \$2.50 each instead of going to the IOKA.

- (a) In one month during the summer, Casey rents 20 movies. What is the average cost of these movies if the price of the DVD player is included?  
 (b) Write an equation that expresses  $A$ , the average cost of a rented movie, as a function of  $n$ , the number of movies rented.  
 (c) For what values of  $n$  is  $A$  less than the price at the IOKA?  
 (d) Casey will of course continue to rent movies. Is there a limit to how low the average cost of a rental can go? If so, what is it? If not, explain why not.

8. Show that  $x = 3 + \sqrt{2}$  is a solution to the equation  $x^2 - 6x + 7 = 0$ .

9. Expand and simplify:

(a)  $(x - 1)(x + 1)$     (b)  $(x - 1)(x^2 + x + 1)$     (c)  $(x - 1)(x^3 + x^2 + x + 1)$

## Mathematics 1

1. Write  $x^5 - 1$  as the product of two factors.
2. Find  $\sqrt{4 + \frac{1}{16}}$  on your calculator. Is the result equivalent to  $\sqrt{4} + \sqrt{\frac{1}{16}}$ ? Explain.
3. Factor each of the following as completely as you can:  
 (a)  $p^4 - 4p^2$       (b)  $w^3 - 2w^2 - 15w$       (c)  $16y - 9yz^2$       (d)  $2x^2 + 20x + 50$

4. The figure shows a bridge arching over the Laconic Parkway. To accommodate the road beneath, the arch is 100 feet wide at its base, 20 feet high in the center, and parabolic in shape.

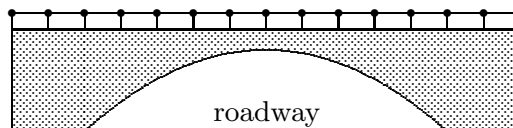

- (a) The arch can be described by  $y = kx(x - 100)$ , if the origin is placed at the left end of the arch. Find the value of the coefficient  $k$  that makes the equation fit the arch.
- (b) Is it possible to move a rectangular object that is 40 feet wide and 16.5 feet high (a wide trailer, for example) through the opening? Explain.

5. There is a unique parabola whose symmetry axis is parallel to the  $y$ -axis, and that passes through the three points  $(1, 1)$ ,  $(-2, -2)$ , and  $(0, -4)$ . Write an equation for it. Given any three points, must there be a parabola that will pass through them? Explain.

6. The  $x$ - and  $y$ -coordinates of a point are given by the equations shown at right. The position of the point depends on the value assigned to  $t$ . Use your graph paper to plot points corresponding to the values  $t = -4, -3, -2, -1, 0, 1, 2, 3$ , and  $4$ . Do you recognize any patterns? Describe what you see.

$$\begin{cases} x = 3 + t \\ y = 5 - 2t \end{cases}$$

7. (Continuation) Plot the points  $(1, 2)$ ,  $(2, 5)$ , and  $(3, 8)$  on the coordinate plane. Write equations, similar to those in the preceding exercise, that produce these points when  $t$ -values are assigned. There is more than one correct answer.

8. Find the solution to each equation:

(a)  $\frac{x}{3} + \frac{x}{5} = 12$       (b)  $\frac{x-2}{-2} = \frac{4x-3}{4}$       (c)  $\frac{x+1}{3} + \frac{x-1}{x} = 2$

9. Sam is a guest on the TV show *Math Jeopardy*, and has just chosen the \$300 question in the category “Quadratic Equations.” The answer is “The solutions are  $x = 3$  and  $x = -2$ .” What question could Sam ask that would win the \$300? Is there more than one possible correct question?

10. What is the distance from the point  $(4, 2)$  to the point  $(-3, -2)$ ? Be prepared to explain your method.

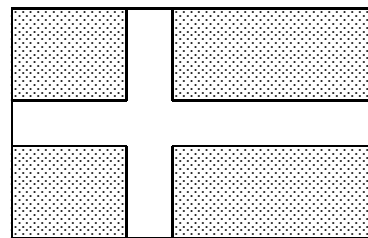

11. The diagram at right shows the flag of Sweden, which consists of a gold cross of uniform width against a solid blue background. The flag measures 3 feet 4 inches by 5 feet 4 inches, and the area of the gold cross is 30% of the area of the whole flag. Use this information to find the width of the gold cross.

## Mathematics 1

- Calculate the following distances, and briefly explain your method:
  - from  $(2, 1)$  to  $(10, 10)$
  - from  $(-2, 3)$  to  $(7, -5)$
  - from  $(0, 0)$  to  $(9, 8)$
  - from  $(4, -3)$  to  $(-4, 6)$
- Halfway through the basketball season, Fran Tastik has made 24 free throws out of 40 shots attempted.
  - What is Fran's average, expressed as a percent?
  - Fran anticipates getting 30 more free throw tries by the end of the season. How many of these must Fran make, in order to have a season average that is at least 70%?
- The distance from here to the beach at Little Boar's Head is 10 miles. If you were to walk at a steady 4 mph, how long would it take you to complete the trip? If you were to ride your bike at 8 miles per hour, how long would it take you to complete the trip? Express the relationship between the speed and the time in an equation. How fast (miles per hour) must you travel if you want to complete this trip in 1 hour? in one minute? in one second?
- Pat and Kim are having an algebra argument. Pat is quite sure that  $\sqrt{x^2}$  is equivalent to  $x$ , but Kim thinks otherwise. How would you resolve this disagreement?
- To get from one corner of a rectangular court to the diagonally opposite corner by walking along two sides, a distance of 160 meters must be covered. By going diagonally across the court, 40 meters are saved. Find the dimensions of the court, to the nearest cm.
- A mathematics teacher wants to make up a quadratic equation  $ax^2 + bx + c = 0$ , so that  $a$ ,  $b$ , and  $c$  are integers, and the correct solutions are  $x = \frac{1}{2}$  and  $x = -3$ . Find values for  $a$ ,  $b$ , and  $c$  that will do the job. Is there more than one equation that will work?
- The distance from  $(0, 0)$  to  $(8, 6)$  is exactly 10.
  - Find coordinates for all the lattice points that are exactly 10 units from  $(0, 0)$ .
  - Find coordinates for all the lattice points that are exactly 10 units from  $(-2, 3)$ .
- Given four numbers  $a$ ,  $b$ ,  $c$ , and  $d$ , one can ask for the distance from  $(a, b)$  to  $(c, d)$ . Write a procedure for computing this distance, using the four numbers.
- The Prep class is going to produce a yearbook covering their first year, compiled from photos and stories submitted by Preps. The printing company charges \$460 to set up and print the first 50 copies; additional copies are \$5 per book. Only books that are paid for in advance will be printed (so there will be no unsold copies), and no profit is being made.
  - What is the cost to print 75 copies? What is the selling price of each book?
  - Write a function that describes the cost of printing  $n$  copies of the book.
  - Write a function that describes the selling price of each book, if  $n$  copies are printed.
  - The Preps want to sell the book for \$6.25. How many books must be sold to do this?
  - If only 125 copies are ordered, what price will be charged per book?
  - For what  $n$  is the selling price less than \$5.05? How low can the selling price be?

## Mathematics 1

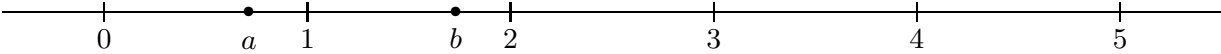
1. The perimeter of a rectangular field is 80 meters and its area is 320 square meters. Find the dimensions of the field, correct to the nearest tenth of a meter.
2. If  $p$  is a positive number, sketch a rough graph of  $y = 2(x - 3p)(x + p)$ . Label its vertex and its  $x$ - and  $y$ -intercepts with coordinates, stated in terms of  $p$ .
3. Find the distance from  $P = (3, 1)$  to  $Q = (x, 1)$ ; from  $P = (3, 1)$  to  $Q = (x, y)$ .
4. Complete the following, without using any variable names: Given two points in a coordinate plane, you find the distance between them by \_\_\_\_\_.
5. Both legs of a right triangle are 8 cm long. In simplest radical form, how long is the hypotenuse? How long would the hypotenuse be if both legs were  $k$  cm long?
6. The hypotenuse of a right triangle is twice as long as the shortest side, whose length is  $m$ . In terms of  $m$ , what is the length of the intermediate side?
7. Can you find integer lengths for the legs of a right triangle whose hypotenuse has length  $\sqrt{5}$ ? What about  $\sqrt{7}$ ? Explain your reasoning.
8. Find as many points as you can that are exactly 25 units from  $(0, 0)$ . How many of them are lattice points?
9. On the number line shown below,  $a$  is a number between 0 and 1, and  $b$  is a number between 1 and 2. Mark possible positions on this line for  $\sqrt{a}$ ,  $\sqrt{b}$ ,  $a^2$ ,  $b^2$ , and  $\sqrt{\frac{b}{a}}$ .  

10. What is the meaning of the number  $k$  when you graph the equation  $y = mx + k$ ? What is the meaning of the number  $k$  when you graph the equation  $x = my + k$ ?
11. A triangle has  $K = (3, 1)$ ,  $L = (-5, -3)$ , and  $M = (-8, 3)$  for its vertices. Verify that the lengths of the sides of triangle  $KLM$  fit the Pythagorean equation  $a^2 + b^2 = c^2$ .
12. A rectangle has an area of 36 square meters. Its length is  $2\sqrt{3}$  meters. In exact form, what is the perimeter of the rectangle?
13. How far is the point  $(5, 5)$  from the origin? Find two other first-quadrant lattice points that are *exactly* the same distance from the origin as  $(5, 5)$  is.
14. Find a quadratic equation that has solutions  $x = 0.75$  and  $x = -0.5$ , and express your answer in the form  $ax^2 + bx + c = 0$ , with  $a$ ,  $b$ , and  $c$  being *relatively prime* integers.
15. Without using a calculator, find the value of  $x^3 - 2x^2y + xy^2$  when  $x = 21$  and  $y = 19$ .

## Mathematics 1

1. At noon one day, AJ decided to follow a straight course in a motor boat. After one hour of making no turns and traveling at a steady rate, the boat was 5 miles east and 12 miles north of its point of departure. What was AJ's position at two o'clock? How far had AJ traveled? What was AJ's speed?
2. (Continuation) Assume that the gas tank initially held 12 gallons of fuel, and that the boat gets 4 miles to the gallon. How far did AJ get before running out of fuel? When did this happen? How did AJ describe the boat's position to the Coast Guard when radioing for help?
3. Sketch the graphs of  $y = \sqrt{x}$  and  $y = \sqrt{x-3}$  on the same system of axes. Describe in words how the two graphs are related. Do they intersect?
4. Sketch the graphs of  $y = \sqrt{x}$  and  $y = \sqrt{x} - 3$  on the same system of axes. Describe in words how the two graphs are related. Do they intersect?
5. Find a quadratic equation of the form  $ax^2 + bx + c = 0$  whose solutions are  $x = 4 \pm \sqrt{11}$ .
6. What is the  $y$ -intercept of the line  $ax + by = c$ ? What is the  $x$ -intercept?
7. Wes and Kelly decide to test their new walkie-talkies, which have a range of six miles. Leaving from the spot where Kelly is standing, Wes rides three miles east, then four miles north. Can Wes and Kelly communicate with each other? What if Wes rides another mile north? How far can Wes ride on this northerly course before communication breaks down?
8. We know that the axis of symmetry for a parabola in the form  $y = ax^2 + bx + c$  can be found from the formula  $x = -\frac{b}{2a}$ . The equation of the axis of symmetry can help us find the  $y$ -coordinate of the vertex. Make the appropriate substitution, using  $x = -\frac{b}{2a}$ , and find a formula for the  $y$ -coordinate of the vertex in terms of  $a$ ,  $b$ , and  $c$ .
9. (Continuation) Find the  $x$ -intercepts of  $y = a(x - h)^2 + k$  in terms of  $a$ ,  $h$ , and  $k$ .
10. (Continuation) Using the fact that  $x = h$  is the axis of symmetry and  $k$  is the  $y$ -coordinate of the vertex, make substitutions in your  $x$ -intercept formulas to express the  $x$ -intercepts in terms of  $a$ ,  $b$ , and  $c$ , rather than  $h$  and  $k$ . Does your answer remind you of another important formula in algebra?
11. Pat and Kim were out in their rowboat one day, and Kim spied a water lily. Knowing that Pat liked a mathematical challenge, Kim demonstrated how it was possible to use the plant to calculate the depth of the water under the boat. Without uprooting the plant, Kim gently pulled it sideways, causing it to disappear at a point that was 35 inches from its original position. The top of the plant originally stood 5 inches above the water surface. Use this information to calculate the depth of the water.

## Mathematics 1

1. Find both solutions to  $3x^2 - 7x + 3 = 0$ . As a check, you should find that the two answers are reciprocals of one another.

2. Draw a right triangle whose legs are 2 cm and 1 cm long, as shown at right. Find the length of its hypotenuse.

(a) Use this hypotenuse as one of the legs of a second right triangle, and construct the other leg so that it is 2 cm long and adjacent to the previous 2-cm leg, as shown. Find the length of the hypotenuse of this right triangle.

(b) Use this hypotenuse as one of the legs of a third right triangle, and construct the other leg so that it is 2 cm long and adjacent to the previous 2-cm leg. Find the hypotenuse of this right triangle.

(c) This process can be continued. What are the lengths of the legs of the next triangle that has a rational hypotenuse? Are there more triangles like this?

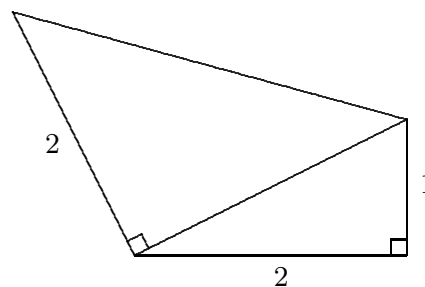

3. After running the 100-yard dash for the first time in Prep track, Taylor set a PEA career goal: to run this race 2 seconds faster. Taylor calculated that this means a rate increase of 5 feet per second. Figure out what Taylor's time was in that first race.

4. The diagram at right shows the flag of Denmark, which consists of a white cross of uniform width against a solid red background. The flag measures 2 feet 11 inches by 3 feet 9 inches, and the area of the white cross is  $\frac{5}{21}$  of the area of the whole flag. Use this information to find the width of the white cross.

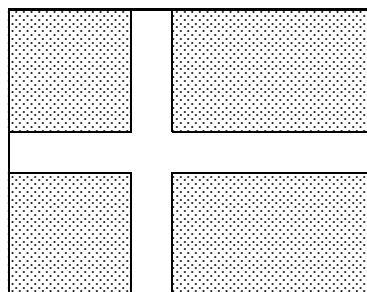

5. Alex is making a 4-mile trip. The first two miles were at 30 mph. At what speed must Alex cover the remaining two miles so that the average speed for the entire trip will be (a) 50 mph? (b) 55 mph? (c) 59.9? (d) 60 mph?

6. Graph the nonlinear equation  $y = 9 - x^2$ , identifying all the axis intercepts. On the same system of coordinate axes, graph the line  $y = 3x - 5$ , and identify its axis intercepts. You should see two points where the line intersects the parabola. First estimate their coordinates, then calculate the coordinates exactly by solving the system of simultaneous equations. Which methods of solution work best in this example?

7. Give an example of a line that is parallel to  $2x + 5y = 17$ . Describe your line by means of an equation. Which form for your equation is most convenient? Now find an equation for a line that is equidistant from your line and the line  $2x + 5y = 41$ .

8. A PEA crew training on the Squamscott River, which has a current of 2 mph, wondered what their rowing rate  $r$  would be in still water. A mathematician in the boat suggested that they row two timed miles — one going upstream and one going downstream. Write an expression that represents their total time rowing these two miles, in terms of  $r$ .

## Mathematics 1

1. A bell rope, passing through the ceiling above, just barely reaches the belfry floor. When one pulls the rope to the wall, keeping the rope taut, it reaches a point that is three inches above the floor. It is four feet from the wall to the rope when the rope is hanging freely. How high is the ceiling? It is advisable to make a clear diagram for this problem.
2. Most positive integers can be expressed as a sum of two or more consecutive positive integers. For example,  $24 = 7 + 8 + 9$ ,  $36 = 1 + 2 + 3 + 4 + 5 + 6 + 7 + 8$ , and  $51 = 25 + 26$ . A positive integer that cannot be expressed as a sum of two or more consecutive positive integers is therefore *interesting*. The simplest example of an interesting number is 1.
  - (a) Show that no other odd number is interesting.
  - (b) Show that 14 is not an interesting number.
  - (c) Show that 82 is not an interesting number.
  - (d) Find three ways to show that 190 is not an interesting number.
  - (e) Find three ways to show that 2004 is not an interesting number.
  - (f) How many interesting numbers precede 2004?
3. On a single set of coordinate axes, graph several parabolas of the form  $y = bx - x^2$ . Mark the vertex on each curve. What do you notice about the configuration of all such vertices?
4. Sketch the graphs of  $y = 2\sqrt{x}$  and  $y = x - 3$ , and then find all points of intersection. Now solve the equation  $2\sqrt{x} = x - 3$  by first squaring both sides of the equation. Do your answers agree with those obtained from the graph?





## Mathematics 1 Reference

**absolute value:** The absolute value of  $x$  is denoted  $|x|$  and is the distance between  $x$  and zero on a number line. The absolute value of a quantity is never negative. [27]

**additive inverse:** See *opposite*.

**average speed:** The average speed during a time interval is  $\frac{\text{total distance}}{\text{total time}}$ . [21]

**average a list of numbers:** Add them and divide by how many numbers in the list. [30]

**axis of symmetry:** A line that separates a figure into two parts that are equivalent by reflection across the line. Every *parabola* has an axis of symmetry. [61,66]

**balance diagram:** A diagram displaying a scale that is in equilibrium. [5]

**binomial:** The sum of two unlike monomials, *e.g.*  $x + 2$  or  $3x^3y - 7z^5$ . [52]

**cc:** Abbreviation for cubic centimeter. See *conversions*.

**coefficient:** See *monomial*.

**collinear:** Three (or more) points that all lie on a single line are collinear. [29]

**combine over a common denominator:** To create a single fraction that is equal to a given sum of fractions. [15]

**common denominator:** Given a set of fractions, a common denominator is divisible by every one of the given denominators. [15]

**common monomial factor:** A *monomial* that divides every term of a *polynomial*. [52]

**completing the square:** Adding a quantity to a trinomial so that the new trinomial can be factored as a perfect square. [65,66,67]

**conjecture:** An unproven statement that seems likely to be true. [56,80]

**consecutive integers:** Two integers are consecutive if their difference is 1. [3]

**continuous:** A variable whose values fill an *interval*. Continuous variables represent quantities that are divisible, such as time and distance. See also *discrete*.

**conversions:** 1 mile = 5280 feet; 1 foot = 12 inches; 1 inch = 2.54 centimeters; one liter is 1000 milliliters; a milliliter is the same as a cubic centimeter.

**coordinate:** A number that locates a point on a number line or describes the position of a point in the plane with respect to two number lines (axes). [6]

## Mathematics 1 Reference

**degree:** For a monomial, this counts how many variable factors would appear if the monomial were written without using exponents. The degree of a polynomial is the largest degree found among its monomial terms. [79]

**direct variation:** Two quantities *vary directly* if one quantity is a constant multiple of the other. Equivalently, the ratio of the two quantities is constant. The graph of two quantities that vary directly is a straight line passing through the origin. [16]

**discrete:** A variable that is restricted to integer values. [37]

**distributive property:** Short form of “multiplication distributes over addition,” a special property of arithmetic. In algebraic code:  $a(b+c)$  and  $ab+ac$  are equivalent, as are  $(b+c)a$  and  $ba+ca$ , for any three numbers  $a$ ,  $b$ , and  $c$ . [1] Multiplication also distributes over subtraction, of course.

**endpoint convention:** If an interval includes an endpoint (as in  $6 \leq x$  or  $y \leq -4$ ), this point is denoted graphically by filling in a circle. If an interval excludes an endpoint (as in  $6 < x$  or  $y < -4$ ), this point is denoted by drawing an empty circle. [10,12]

**equation:** A statement that two expressions are equivalent. For example,  $3x+5 = 2x-4$ ,  $\frac{3}{4} = \frac{15}{20}$ , and  $(x+3)^2 = x^2 + 6x + 9$  are all equations. [3] The last one is an *identity*.

**evaluate:** Find the numerical value of an expression by *substituting* numerical values for the *variables*. For example, to evaluate  $2t + 3r$  when  $t = 7$  and  $r = -4$ , substitute the values 7 and  $-4$  for  $t$  and  $r$ , respectively. [2]

**exponent:** An integer that indicates the number of equal factors in a product. For example, the exponent is 3 in the expression  $w^3$ , which means  $w \cdot w \cdot w$ . [44]

**exponents, rules of:** These apply when there is a *common base*:  $a^m \cdot a^n = a^{m+n}$  and  $\frac{a^m}{a^n} = a^{m-n}$ ; when there is a *common exponent*:  $a^m \cdot b^m = (a \cdot b)^m$  and  $\frac{a^m}{b^m} = \left(\frac{a}{b}\right)^m$ ; or when an exponential expression is raised to a power:  $(a^m)^n = a^{mn}$ . Notice the special case of the common-base rules:  $a^0 = 1$ .

**extrapolate:** To enlarge a table of values by going outside the given range of data. [25]

**factor:** *Noun:* a number or expression that divides another number or expression without remainder. For example, 4 is a factor of 12,  $2x$  is a factor of  $4x^2 + 6xy$ . *Verb:* to rewrite a number or an expression as a product of its factors. For example, 12 can be factored as  $2 \cdot 2 \cdot 3$ , and  $4x^2 + 6xy$  can be factored as  $2x(2x + 3y)$ . [42]

**factored form:** Written as a product of factors. For example,  $(x-3)(2x+5) = 0$  is written in factored form. If an equation is in factored form it is particularly easy to find the solutions, which are  $x = 3$  and  $x = -\frac{5}{2}$  in this example. [49]

## Mathematics 1 Reference

**feasible region:** A region of the plane defined by a set of inequalities. The coordinates of any point in the feasible region satisfy all the defining inequalities. [52]

**function:** A function is a rule that describes how the value of one quantity (the dependent variable) is determined uniquely by the value of another quantity (the independent variable). A function can be defined by a formula, a graph, a table, or a text. [62]

**greatest common (integer) factor:** Given a set of integers, this is the largest integer that divides all of the given integers. Also called the *greatest common divisor*.

**greatest common (monomial) factor:** Given a set of *monomials*, this is the largest monomial that divides all of the given monomials. [52]

**guess-and-check:** A method for creating equations to solve word problems. In this approach, the *equation* emerges as the way to check a *variable* guess. Initial practice is with constant guesses, so that the checking can be done with ordinary arithmetic. [9,10,11]

**hypotenuse:** In a right triangle, the side opposite the right angle. This is the longest side of a right triangle. [79]

**identity:** An *equation*, containing at least one *variable*, that is true for all possible values of the variables that appear in it. For example,  $x(x + y) = x^2 + xy$  is true no matter what values are assigned to  $x$  and  $y$ . [39]

**inequality:** A statement that relates the positions of two quantities on a number line. For example,  $5 < x$  or  $t \leq 7$ . [12]

**integer:** A whole number — positive, negative, or zero. [2]

**interpolate:** To enlarge a table of values by staying within the given range of data. [25]

**interval:** A connected piece of a number line. It might extend infinitely far in the positive direction (as in  $-1 < x$ ), extend infinitely far in the negative direction (as in  $t \leq 7$ ), or be confined between two endpoints (as in  $2 < m \leq 7$ ).

**irrational number:** A number that can not be expressed exactly as the ratio of two integers. Two familiar examples are  $\pi$  and  $\sqrt{2}$ . See *rational number*. [61]

**lattice point:** A point both of whose coordinates are integers. The terminology derives from the rulings on a piece of graph paper, which form a lattice. [31]

**like terms:** These are *monomials* that have the same variables, each with the same exponents, but possibly different numerical coefficients. Like terms can be combined into a single monomial; unlike terms cannot. [7]

## Mathematics 1 Reference

**linear:** A polynomial, equation, or function of the first degree. For example,  $y = 2x - 3$  defines a linear function, and  $2x + a = 3(x - c)$  is a linear equation. [23,62]

**linear combinations:** A method for solving systems of linear equations. [37,38,40]

**London Philharmonic Orchestra.** [204]

**lowest terms:** A fraction is in lowest terms if the greatest common factor of the numerator and denominator is 1. For example,  $\frac{14}{21}$  is not in lowest terms because 14 and 21 have 7 as a common factor. When numerator and denominator are each divided by 7 the resulting fraction  $\frac{2}{3}$  is equal to  $\frac{14}{21}$ , and is in lowest terms.

**model:** An equation (or equations) that describe a context quantitatively. [6]

**monomial:** A product of variables (no additions, subtractions, or divisions) times an optional constant, called the *coefficient*. For example,  $ax^2$  and  $3x^5$  are monomials. [51] See also *binomial*, *polynomial*, and *trinomial*.

**multiplicative inverse:** See *reciprocal*.

**number line:** A line on which two points have been designated to represent 0 and 1. This sets up a one-to-one correspondence between numbers and points on the line. [2]

**opposite:** When the sum of two quantities is zero, they are called opposites (or *additive inverses*); each is the opposite of the other. On a number line, zero is exactly midway between any number and its opposite. [3]

**or:** Unless you are instructed to do otherwise, interpret this word *inclusively* in mathematical situations. Thus a phrase "... (something is true) or (something else is true) ..." allows for the possibility that *both* (something is true) and (something else is true).

**parabola:** The shape of a graph of the form  $y = ax^2 + bx + c$ . All parabolas have a *vertex* and an *axis of symmetry*. [62]

**perimeter:** The total length of the sides of a figure. The perimeter of a rectangle is twice the length plus twice the width. In algebraic code,  $p = 2l + 2w = 2(l + w)$ . [9]

**period of a pendulum:** The time needed for a pendulum to swing back and forth once. [82]

**point of intersection:** A point where one line or curve meets another. The coordinates of a point of intersection must satisfy the equations of the intersecting curves. [35]

**point-slope form:** The line with slope  $m$  that passes through the point  $(h, k)$  can be described in point-slope form by either  $y - k = m(x - h)$  or  $y = m(x - h) + k$ . [27]

## Mathematics 1 Reference

**polynomial:** A sum of *monomials*. See also *binomial* and *trinomial*. [52]

**proportion:** An *equation* stating that two *ratios* are equal. For example,  $\frac{4}{6} = \frac{6}{9}$  is a proportion. [17]

**Pythagorean Theorem:** The square of the length of the *hypotenuse* of a right triangle equals the sum of the squares of the lengths of the other two sides. [79]

**quadratic equation:** A polynomial equation of degree 2. [63]

**quadratic formula:** The solution to the quadratic equation  $ax^2 + bx + c = 0$ , which can be written as  $x = \frac{-b \pm \sqrt{b^2 - 4ac}}{2a}$ . [75]

**quadratic function:** A function defined by an equation of the form  $y = ax^2 + bx + c$ , where  $y$  is the dependent variable. The word quadratic comes from a Latin word that means “to make square”, and it refers to the presence of a squared variable in the equation. [63]

**radical expression:** An expression containing roots, like  $\sqrt{2}$  or  $\sqrt{x - 3}$ . [67]

**rate (of change):** Rate often denotes speed, *i.e.* units of distance per unit of time. For example, 60 miles per hour, 50 feet per second, 67 furlongs per fortnight. A general rate of change is similar: number of units of A *per* one unit of B. For example, 5 liters per student, 24 angels per pinhead, 1.3 thousand persons per year, 70 passengers per lifeboat. [1,2,19,20]

**ratio:** The ratio of  $a$  to  $b$  is the expression  $\frac{a}{b}$ ; also written  $a:b$  or  $a/b$  or  $a \div b$ . [10]

**rational number:** A number that can be written as the ratio of two integers. For example, 5,  $\frac{7}{13}$ , and 0.631 are rational numbers. See also *irrational number*. [61]

**reciprocal:** When the product of two quantities is 1, they are called reciprocals (or *multiplicative inverses*); each is the reciprocal of the other. For example, 0.2 is the reciprocal of 5, and  $\frac{a}{b}$  is the reciprocal of  $\frac{b}{a}$ . Any nonzero number has a reciprocal. [5]

**relatively prime integers** have no common divisor that is larger than 1. [88]

**Scandinavian flags** are all based on the *Dannebrog*. [80,86,90]

**scatter plot:** The graph of a discrete set of data points. [24]

**simplest radical form:** An expression  $a\sqrt{b}$  is in simplest radical form if  $b$  is a positive integer that has no factors that are perfect squares. For example,  $18\sqrt{5}$  is in simplest radical form, but  $5\sqrt{18}$  is not. [64]

## Mathematics 1 Reference

**simultaneous solution:** A solution to a system of equations must satisfy *every* equation in the system. [37]

**slope:** The slope of a line is a measure of its steepness. It is computed by the ratio  $\frac{\text{rise}}{\text{run}}$  or  $\frac{\text{change in } y}{\text{change in } x}$ . A line with positive slope rises as the value of  $x$  increases. If the slope is negative, the line drops as the value of  $x$  increases. [14]

**slope-intercept form:** The line whose slope is  $m$  and whose  $y$ -intercept is  $b$  can be described in slope-intercept form by  $y = mx + b$ . [23]

**solve:** To find the numerical values of the variables that make a given equation or inequality a true statement. Those values are called *solutions*. [6]

**square:** To multiply a number by itself; *i.e.*  $b^2$  is the square of  $b$ .

**square root:** A square root of a nonnegative number  $k$  is a number whose square is  $k$ . If  $k$  is positive, there are two such roots. The positive root is denoted  $\sqrt{k}$ , and sometimes called “the square root of  $k$ .” The negative root is denoted  $-\sqrt{k}$ .

**standard form:** A linear equation in the form  $ax + by = c$ . [28]

**substitution:** Replacing one algebraic expression by another of equal value. [41]

**system of equations:** A set of two or more equations. The solution to a system of linear equations is the coordinates of the point where the lines meet. The solution is the values of the variables that satisfy all the equations of the system at the same time. [37]

**triangular number:** Any integer obtained by summing  $1 + 2 + \cdots + n$ , for some positive integer  $n$ . [75]

**trinomial:** The sum of three unlike monomials, e.g.  $x^2 - x + 2$  or  $3x^3y - 7x^5 + 8qrs$ . [52]

**variable:** A letter (such as  $x$ ,  $y$ , or  $n$ ) used to represent a number. A few letters (such as  $m$  and  $n$ ) tend to be associated with integers, but this is not a rule. [2]

**vertex:** A “corner” point on an absolute-value graph. [31] The vertex of the graph  $y = a|x - h| + k$  is  $(h, k)$ . The vertex of the graph of a quadratic function is the point whose  $y$ -coordinate is extreme (highest or lowest). It is the point on the parabola that is also on the axis of symmetry. [61,66] The vertex of the graph  $y = a(x - h)^2 + k$  is  $(h, k)$ . [72]

**water lily:** In 1849, Henry Wadsworth Longfellow wrote his novel *Kavanaugh*, which contained several mathematical puzzles. One was about water lilies. [89]

## Mathematics 1 Reference

**x-intercept:** The  $x$ -coordinate of a point where a line or curve meets the  $x$ -axis. [23]

**y-intercept:** The  $y$ -coordinate of a point where a line or curve meets the  $y$ -axis. [23]

**zero-product property:** If the product of a set of factors is zero, then at least one of the factors must be zero. In symbols, if  $ab = 0$  then either  $a = 0$  or  $b = 0$ . [63]